



C A T A L O G U E

*Today's Products. Tomorrow Technologies*



---

**We proudly distribute these Brands**

---



## PT. EKASURYA INOUT INDONESIA

Was established in the mid of August 2000 and throughout the years our company has improved and progressed leaps and bounds. Not only do we partnership with more global brands, but we have also expand our capacity and capability to better serve our customers. And to date we offer more than 4.000 kinds of products cater for all industrial and commercial needs.

## Vision & Mission

Creating a great place where people can work, share, and inspire others, in order to serve and become a qualified trading manufacturing company; professional & competitive in a global marketing network.





# Wiping Solutions



## WYPALL\* X60 Jumbo Roll Wipers

- Quantity = 900 sheets per roll
- Highly absorbent wiper and an excellent choice to replace rags or "kain majun"
- Application: cleans and absorb liquid, oil and grease from surfaces and equipment.

CODE 93495



## WYPALL\* X70 Quarterfold Wipers

- Quantity = 90 sheets per pack
- Improved absorption, with Power-Pocket Technology, of liquid spills, oil and grease.
- Produced in HACCP certified facility.
- Suitable for preparing surfaces with solvents.

CODE 95412



## WYPALL\* L10 Roll Control Wipers

- Quantity = 1 Ply, 790 sheets per roll
- They are HACCP Certified, 100% Cellulose contain no glues or additives.
- Application: hand drying and food preparation.

CODE 28053



## WYPALL\* L20 Perforated Jumbo Roll Wipers

- Quantity = 956 sheets per roll
- The wipers incorporate patented technology improving durability for wet and dry use.
- Economical choice, ideal for paper mills, metal fabrication, assembly plants, etc.

CODE 96232



## KIMTECH SCIENCE\* KIMWIPES\* Delicate Task Wipers

- Soft and non-abrasive, safe for most delicate surfaces and easily wipe up liquid and dust.
- Low lint - ideal for use on delicate parts and instrument such as electronic equipment, optical products and laboratory equipment.

CODE 34155, 34156



## KIMTECH PREP\* KIMTEX\* Wipers

- Quantity: 66 sheets per pack
- Engineered for critical applications involving solvents, inks, and paints.
- Ideal for printing, engine assembly/repair, LCD panel assembly, glass and mirror cleaning, etc.

CODE 33560



## KIMTECH\* W4 Cleanroom Wipers

- Meet USDA requirements for food processing establishments.
- Ideal for surface wiping in ISO Class 4 or higher cleanroom environment.

CODE 33330



## KIMTECH\* Wipers for the WETTASK System

- Add your own chemical solution, such as quaternary amines, bleach, and solvent, to create a customised pre-saturated wiper for preparing, cleaning, disinfecting or sanitising surfaces.

CODE 06411



## WYPALL\* Microfiber with MICROBAN® Protection

- Remarkably absorbent, able to hold up to 8 times their weight in liquid
- Produced in a HACCP manufacturing facility
- Different colors for easy task segregation and reduce risk of cross contamination.

CODE 84610, 84620, 84630,  
84980, 94228, 94229



### WYPALL\* Color Coded Wipers

- Produced in HACCP certified facility, ideal for use in food preparation and
- food service applications.
  - Reusable and available in different colors for easy task segregation and
  - reduce the risk of cross contamination.

CODE 94151, 94147, 94144, 94143,  
94153, 94164



### SCOTT\* Airflex\* Hard Roll Hand Towel

- Hand towels on high-capacity rolls that control how much tissue you take and help cut costs and waste.
- Received endorsement and/or approval from HACCP International

CODE 86220



### Kimberly-Clark Oil Sorbent Pads & Socks

- **Pads:** Ideal to control leaks and spills of lubricant oil, diesel, hydraulic fluids, gear lube, gasoline and heating oil.
- **Socks:** Ideal for preventing oil leakage on irregular surfaces.

CODE 42411, 94202

## Accessories



### WYPALL\* Floor Unit Dispenser

- Easy to carry and move around your production area.

CODE 80596



### WYPALL\* Wall Mount Dispenser

- Fixed in one place
- Ideal for busy work areas with high usage.

CODE 80579



### KIMBERLY-CLARK\* Roll Control Dispenser

- Lockable plastic dispenser discourages pilferage and waste.

CODE 99337

## Automotive Wipers



### KIMTECH\* Primary Tack Cloth

- Excellent low lint performance which is designed for automotive paint-shop use and with sealed edges to ensure that the fibers are held in.
- Solvent, silicone and wax-free materials.
- No VOCs (Volatile Organic Compounds)

CODE 38712



### KIMTECH\* Knitted Polyester Wiper

- Virtually lint free and is solvent compatible.

CODE 38714



### KIMTECH\* Un-Dyed Microfiber Cloths

- Is up to 50% more absorbent than other microfibre cloths

CODE 38715



# Safety Solutions



## **KLEENGUARD\* G10 Arctic Blue Nitrile Gloves**

- Latex free and Powder free
- Food contact approved
- Suitable for: automotive, transport, cleaning and engineering industries, food processing and catering

**CODE** 90096, 90097, 90098



## **KLEENGUARD\* G10 Grey Nitrile Gloves**

- Latex free and Powder free
- Food contact approved
- Suitable for: automotive, transport, cleaning and engineering industries, food processing and catering

**CODE** 97821, 97822, 97823



## **KLEENGUARD\* G10 Flex Nitrile Gloves**

- Excellent choice for economical nitrile gloves
- Available in color: Blue & White.
- Suitable for: automotive, transport, cleaning and engineering industries, food processing and catering

**CODE** 38520, 38521, 38525, 38526



## **KLEENGUARD\* G20 Blue Nitrile Gloves**

- Protection to light chemical splash
- Latex free and Powder free
- Suitable for: light chemical handling, painting, printing, automotive assembly, emergency services.

**CODE** 38708, 38709



## **Kimberly-Clark\* Purple Nitrile\* Xtra\* Exam Gloves**

- 12" long, Latex free and Powder-free
- Tested for use with ten chemotherapy drugs
- Suitable for: pharmaceutical, chemical handling, automotive assembly, emergency services, food industry.

**CODE** 50601, 50602, 50603



## **JACKSON SAFETY\* G80 Nitrile Chemical Resistance Gloves**

- Protection against a broad range of chemicals including Oils, Solvents, Greases, Acids, and Caustics
- Abrasion resistance level 4
- Suitable for: chemical handling, automotive, agriculture, contract cleaning, janitorial and public service

**CODE** 94446, 94447, 94448



## **JACKSON SAFETY\* G40 Latex Coated Gloves**

- General purpose hand protection
- EN388: 2142
- Suitable for: automotive assembly, general manufacturing, warehouse, transport construction.

**CODE** 97271, 97272



## **JACKSON SAFETY\* G40 Nitrile Coated Gloves**

- Premium, general purpose hand protection
- EN388: 4131
- Size available: M/8, L/9
- Suitable for: automotive assembly, general manufacturing, public sector service, transport construction.

**CODE** 40226, 40227



## **JACKSON SAFETY\* G40 Polyurethane Coated Gloves**

- Versatile, general purpose hand protection
- Excellent grip when use wet
- EN388: 3131
- Suitable for: automotive, electronics, general manufacturing, public sector service.

**CODE** 13838, 13839, 13840



**JACKSON SAFETY\* G60  
Level 3 Purple Nitrile\*  
Cut Resistance Gloves**

- Nitrile dots on palm offer excellent grip
- EN388: 4340
- Suitable for: metal fabrication, glass handling, handling sharp objects, automotive assembly.

**CODE** 97430, 97431, 97433



**JACKSON SAFETY\* G60  
Level 3 Knuckle Coated  
Cut Resistance Gloves**

- PU Coating offers excellent grip and knuckle protection
- EN388: 4342
- Suitable for: confined space, metal fabrication, glass handling, handling sharp objects, automotive assembly.

**CODE** 38732, 38733



**JACKSON SAFETY\* H10  
Hearing Protection**

- Disposable earplugs. Un-corded.
- Free from latex, silicone and phthalates
- High visibility for easy compliance monitoring
- Each pair individually bagged

**CODE** 67220



**JACKSON SAFETY\* H20  
Hearing Protection**

- Reusable Earplugs. With cord.
- Free from latex, silicone and phthalates
- High visibility for easy compliance monitoring
- Each pair complete with re-sealable bag

**CODE** 67221



**JACKSON SAFETY\* R10 N95  
Dual-Valved Particulate Respirators**

- NIOSH N95 and EN FFP1 approved
- Dual Valves - to maximise airflow and help reduce fogging on eye wear
- Protection against: Fine dust & water and oil based mists

**CODE** 64260



**JACKSON SAFETY\* R10 N95  
Particulate Respirators**

- NIOSH N95 and EN FFP1 approved
- Soft nose foam with cloth layer designed to improve comfort and reduce fogging on safety eye protection
- Protection against: fine dusts & water and oil based mists.

**CODE** 64230



**JACKSON SAFETY\* R20 P95  
Particulate Respirators**

- NIOSH P95 approved.
- Single - Exhalation valve designed for heat and moisture reduction to provide enhanced comfort
- Protection against: fine dusts, water and oil based mists and metal fumes.

**CODE** 64420



**KLEENGUARD\* A40  
Liquid & Particle Protection Apparel**

- Suitable for critical production environments such as pharmaceutical industries, manufacturing, electronics, agriculture and paint spraying.
- Anti-static fabric EN 1149-1 for critical areas

**CODE** 99790, 99791, 99792, 99793



**KLEENGUARD\* A70  
Chemical Protection Apparel**

- Typical Uses: hazardous waste remediation, environmental cleanup, petrochemical/oil refining, acid/caustic handling, biohazard cleanup, tank cleaning, pharmaceutical manufacturing

**CODE** 9812, 9813, 9814



**JACKSON SAFETY\* V50  
OTG (Over The Glass)**

- Meets ANSI Z87.1+ Standard
- Offers OTG (fits over most prescription eyewear), as well as anti-fog coating, foam and particle shields.
- Adjustable side frame for added comfort.

**CODE** 48200



**JACKSON SAFETY\* V80  
MONOGOGGLE\* XTR\* Goggles**

- Meet ANSI Z87.1 + standards
- Protects against splashes, while providing increased visibility due to its cylindrical lens.
- Indirect ventilation.

**CODE** 18624



**JACKSON SAFETY\* V90  
SHIELD\* Goggles**

- Meet ANSI Z87.1 + standards
- The Monogoggle\* XTR\* Goggles with indirect ventilation and a polycarbonate shield for full face protection
- Shield detaches from the goggle

**CODE** 18629



### JACKSON SAFETY\* V30 Nemesis Indoor Outdoor

- Meets ANSI Z87.1 : 2010, EN 166 : 2001
- 99.9% UVA/UVB Protection
- Impact resistant polycarbonate lens
- Every pair includes a neck cord

CODE 20381



### JACKSON SAFETY\* V20 PURITY\* Clear Anti Fog

- Meets ANSI Z87.1 : 2010, EN 166 : 2001
- 99.9% UVA/UVB Protection
- Impact resistant polycarbonate lens

CODE 25654



### JACKSON SAFETY\* V30 Nemesis Smoke Mirror

- Meets ANSI Z87.1 : 2010, EN 166 : 2001
- 99.9% UVA/UVB Protection
- Impact resistant polycarbonate lens
- Every pair includes a neck cord

CODE 20380



### JACKSON SAFETY\* WH10 Welding Helmet

- A lightweight black welding helmet with clear face shield and single 90x110mm mineral-glass DIN 11 passive filter, fitted with a quick-release clip mechanism for replacement filters and protective lenses.

CODE J80330



### JACKSON SAFETY\* WH20 Welding Helmet

- Suitable for specialised welders who need flexibility to adapt to a wider number of welding and torch cutting conditions in busy, high-productivity environments

CODE J80420



### JACKSON SAFETY\* WH30 Welding Helmet

- Suitable for professional welders who need various filter options to help reduce different welding and torch cutting risks, in demanding high-productivity environments.

CODE J80270

## Industrial Hand Cleaner



### Scott® Naturally Tuff Orange (NTO) with Grit

- Naturally Tuff Orange (NTO) Hand Cleaner are made with 'scrubber beads' for the toughest jobs, including oil, grease and tar.
- This hand cleaner can be applied with or without water.

CODE 12507



### Scott\* Super Duty Skin Cleanser with Grit

- Formulated to clean the toughest dirt, including grease and tar. It contains no petroleum solvents.
- Use water to rinse and clean.
- Available with the Sanituff® Push Dispenser.

CODE 11757



## Silicone Solutions for Electronic Devices and Component Assemblies

### Silicone Product Profile

The products introduced in this selector guide consist of "RTV" (Room Temperature Vulcanizing) silicone products, that are commonly found in Electric and Electronic applications and component assemblies. This family of silicone products consists of both Room Temperature Cure and Heat (Addition) Cure grades.

Momentive Performance Materials offers a comprehensive portfolio of silicone solutions to help meet a broad array of handling and performance needs in electronic components and assemblies. Selection of the appropriate type of RTV depends upon the required manufacturing process, handling requirements, curing conditions, equipment, and desired material properties.

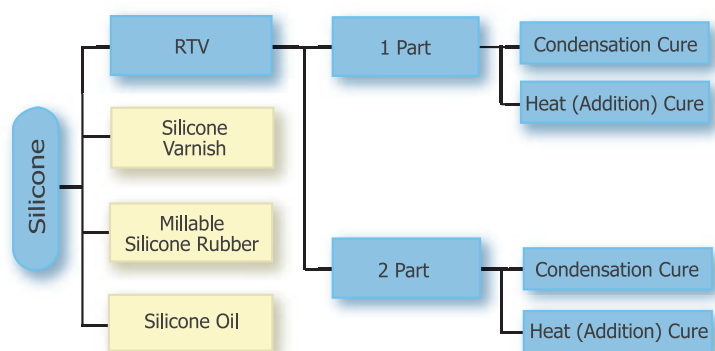

#### Condensation Cure

Condensation cure silicone products cure when exposed to moisture in the environment at room temperature. These materials are categorized into Alkoxy, Acetoxy, or Oxime based on the byproducts that occur during cure.

#### Heat (Addition) Cure

Heat cure grades cure upon exposure to elevated heat or room temperature.

### Relative Performance Characteristics

Property	Silicone RTV	Epoxy	Urethane
Temperature Range	-50 ~ +200°C	-50 ~ +150°C	-30 ~ +120°C
Heat Resistance	Excellent	Poor	Poor
Flame Retardancy*	Excellent	None	None
UV Stability	Excellent	Poor	Poor
Ozone Stability	Excellent	Poor	Poor
Modulus	Low	High	High

\* As a base material, silicone demonstrates flame retardant properties comparable to UL94HB.

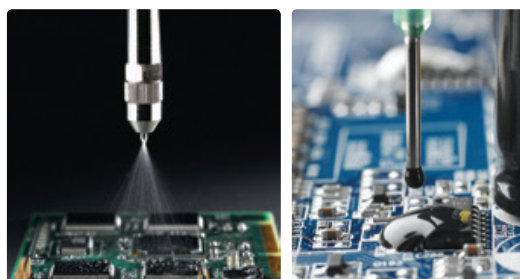

### Product Offers

#### Potting Gel /Encapsulant

- Heat Cure
- Condensation Cure

#### Conformal Coating

- Condensation Cure
- Additional Cure

#### Thermal Interface Adhesive

- Grease
- Adhesive
- Potting Materials

#### Roller Materials

- Conductive

#### Sealant

- Adhesive
- Low Volatile

# LOCTITE

## Industrial Adhesives

### Threadlocking



FEATURES	SOLUTIONS	YOUR BENEFITS
High temperature Resistance	271 272 2701	Medium viscosity; high strength; resists vibration; Suitable for all metal fastener.
General Purpose	243 248	Medium bond strength; Works on all metals, including passive substrates; Proven to tolerate minor contamination by industrial oils
Wicking Grade	290	Medium/high-strength; Ideal for locking preassembled fasteners, e.g. electrical connectors and set screws; Works on metal only.
Easy Removable	222	Ideal for low-strength threadlocking of adjusting screws, countersunk head screws and set screws; Suitable for small thread sizes.

### Instant Bonding



FEATURES	SOLUTIONS	YOUR BENEFITS
General Purpose	401, 406, 454, 495, 28626	Low viscosity. Ideal for all quick repairs and for use on porous substrates; Very high strength on close-fitting parts; Bonds a wide range of similar or dissimilar substrates (metals, rubber, wood, cardboard, leather, fabric, ceramics as well as most plastics)
Health and Safety Instant Adhesives	403, 408, 460	Classified as non-irritant, these adhesives are colourless with low bloom and low odour. Ideal for bonding porous/acidic substrates such as wood, paper, leather and cork as well as plastics, rubber and metals.
High Toughness	435, 480	Ideal for bonding metal to metal, to rubber or magnet, also suited to plastics, rubbers, and porous/acidic surfaces; High resistance to impact and shock loads.
Methyl-based Instant Adhesive	493	A transparent, colourless, methyl-based instant adhesive that is particularly suited to bonding metals; 10 - 30 secs fixture time

## Retaining



FEATURES	SOLUTIONS	YOUR BENEFITS
High Temperature	638, 648, 668	Ideal for retention of parts with a clearance or interference fit; Well suited for bonding of cylindrical fitting parts; High strength on all metals, including passive substrates (e.g. stainless steel).
Large Gap	660	Retaining Compound - high strength. Gap filling. For repair of worn-out seats, keys, splines, bearings or tapers without remachining; Suitable for retaining shims.

## Industrial Sealants



FEATURES	SOLUTIONS	YOUR BENEFITS
Polymer	Teroson MS 930, Teroson 9120, Teroson MS931, Teroson MS 939	Sealant based on silane modified polymer, which cures by reaction with moisture to a soft elastic product. The skin formation and curing times are dependent on humidity and temperature, and the curing time also depends on joint depth
Silicone	5610 A&B, 5145, 5366, 5398, 5399	Specially formulated for perfect sealing. Rapid cure time. Good bond strength on glass and metals. Temperature resistance.

## Structural Bonding



FEATURES	SOLUTIONS	YOUR BENEFITS
Epoxy	E20HP, E0OCL	Low viscosity, fast setting, high strength multi-surface structural adhesive with a 5-min and 20-min worklife.
Acrylic	326, 330	Suited to magnet bonding also dissimilar substrates like PVC, phenolic and acrylic compounds; Medium to high viscosity; good adhesion to different types of ferrites; Activator required.

## Light Cure Adhesive



FEATURES	SOLUTIONS	YOUR BENEFITS
UV Light Cure Adhesive	3106, 3504, 352	Good resistance to chemicals and high humidity. Ideal for stress-sensitive plastics, glass, metals and ceramics. Fixture tim 10 - 15sec.  Service temperature range is -40°C to +130°C.

## Silicone Adhesive



FEATURES	SOLUTIONS	YOUR BENEFITS
Silicone Adhesives	5145, 5699, 5999	Ideal for bonding, sealing, and coating of electronic devices, especially for military, automotive and industrial electronic.

## Primer



FEATURES	SOLUTIONS	YOUR BENEFITS
Activator	7649, 7109, 770, 7387, 7639, 7452	Designed to promote the curing speed of LOCTITE adhesives and sealants without any significant loss of joint strength.

## Thermal Management Materials

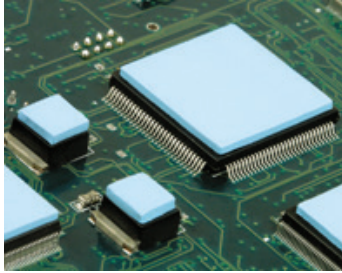

FEATURES	SOLUTIONS
LOCTITE	384, TC8M WH, TG100, TCP8010
BERGQUIST	Gap Pad, Gap Filler, Thermal Interface Compound, Hi-Flow, Thermal conductive insulator, Bond-Ply and Liqui-Bond
Activator	7387

## Surface Mount Adhesive



FEATURES	SOLUTIONS
LOCTITE	3609, 3619, 3621, 3621B, 3629, 3629C
Screen Printing / Pin Transfer	3616, 3627, 3626
Cleaner	7360

## Potting & Encapsulating

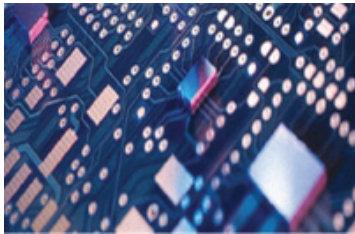

	FEATURES	SOLUTIONS	YOUR BENEFITS
Chip On Board Encapsulation	Glob Top UV Material	UV8800, 3327	Compounds used to provide mechanical reinforcement to housed assemblies, to fill large voids, and to protect components from the exposure to chemicals, moisture, mechanical shock and vibration
	Glob Top Thermal Material	EO1016, EO1061, EO1062, EO1072, FP4323, FP4401	
	Dam Materials	FP4451, FP4451TD	
	Fill Material	FP4450, FP4450LV, FP4450HF, FP4470	
Circuit Board Protection	Polyamide	OM673, OM682, OM678, OM687, OM633, OM652	Coatings protect a substrate from a variety of environmental problems such as: corrosion of solder joints, moisture and mildew, fuels and process solvents, service temperatures, and dust, dirt and physical damage from handling.
	Polyolefin	AS5375	

# LOCTITE

## Equipment Solutions



### ROBOT DISPENSING SYSTEM



#### Loctite® 300D Benchtop Robot System

CODE 1597107

- Low-cost benchtop robot
- 300 x 300 x 100 mm range, 3-axis control
- Has features and accessories that are custom tailored for adhesive dispensing process
- Also available: **Teach Pendant (code 1328356)** to program the line of D Series Dispensing Robot.

### LED & LIGHT CURE SOLUTION

#### Loctite® LED & UVV Dosimeter (UVA & UVB)

CODE 1390323, 1265282

- Measure the UV Dose (energy) and UV Intensity of UV and Visible Light Curing devices

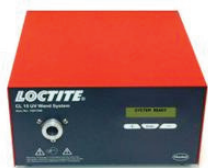

#### Loctite® CL15 UV Wand System

CODE 1661548

- Ideal for both continuous or batch processing of assemblies that require light curing in relatively small areas

#### Loctite® Flood Cure Array 405 nm Wavelength

CODE 1167593

- The Flood Array produces a curing area of 100 mm x 100 mm (4 inches by 4 inches).



#### Loctite® 7700-HD LED Light Source

CODE 1427232

- Designed for continuous duty usage and is equipped with an internal cooling fan.
- Virtually eliminates substrate heating and emits in the 390 to 420 nm wavelengths.

## HANDHELD APPLICATORS

### Loctite® 30ml Manual Syringe Dispenser

CODE 1544934

- A hand-held, manually operated dispenser, for any product packaged in a standard 30ml syringe.



### Loctite® 50 ml Dual Cartridge Manual Applicator

CODE 720228

- A hand-held, manually operated meter-mix dispenser.
- These dispensers provide a convenient, cost-effective method to apply product with minimal waste.
- Also available: **Loctite® 400 ml Dual Cartridge Manual Applicator (code 218312)**

### Fixmaster® Universal Dispenser

CODE 1372751

- A hand-held, manually operated gun that was designed specifically for dispensing two-component adhesives packaged in either 200 ml or 400 ml dual cartridges.



### Loctite® 50 ml Bottle Hand Pump

CODE 608966

- A portable, precision, bottle-top applicator that threads firmly onto any 50 ml anaerobic bottle.
- Also available: **Loctite® 250 ml Bottle Hand Pump (code: 88631)**

### Loctite® 50ml Dual Cartridge Pneumatic Applicator

CODE 476898

- A hand-held pneumatically operated dispenser.
- The applicator can accept various 50 ml dual cartridges of 1:1 and 2:1 mix ratio products and 35 ml dual cartridges of 10:1 mix ratio products.
- Also available: **Loctite® 400 ml Dual Cartridge Pneumatic Manual Applicator (code: 218311)**



### Loctite® EQ HD10 300ml Pneumatic Cartridge Applicator

CODE 1714379

- A manually controlled applicator that dispenses product from 300 ml cartridges.
- The cartridge is pneumatically pressurized and product is dispensed from the nozzle while the trigger is depressed.

## DISPENSE SYSTEM

### Loctite® Posi-Link 10-50 Actuator

CODE 756475

- Provides adhesive dispensing by effecting incremental movements of a piston and displacing programmable quantities of adhesive with syringe barrel or dual cartridge





**Loctite®  
Dual Channel Integrated Dispensers**

**CODE** 1390321

- The controller provides 2 independent digital timing channels that provide control of 2 pneumatic outputs.

**Loctite®  
Digital Syringe Dispenser**

**CODE** 883976

- A semi-automatic dispensing system designed to dispense Loctite adhesives and fluids packaged in 3, 5, 10, 30, 55 syringes and 300 ml cartridges.



**Loctite®  
Cyanoacrylate Dispense Valve**

**CODE** 318654

- This valve is suitable for all low to medium viscosity cyanoacrylate adhesives.
- The valve has a small profile with a 0.9 inch diameter and 2.5 inch length.
- Also available: **Loctite® Light Cure Dispense Valve (code: 218280)**

**Loctite®  
Benchtop Peristaltic Dispenser**

**CODE** 769914

- It is great for precise dosing or applications that require a specific flow rate.
- Electro-mechanically operated and does not require the use of an air source.



# TEROSON®

## VEHICLE REPAIR & MAINTENANCE



**1 PENETRANT OIL**

- **Loctite® ML-11** - Lubricant, Cleaner, Rust Protection

**2 SEALANTS**

- **Teroson PU 9092** - Glass Sealant
- **Teroson MS 930** - Body Sealant

**3 SILICONE GASKET**

Non-corrosive, for flange with permanent water/glycol contact

- **Loctite® RTV 5699 GREY Maxx Silicone**
- **Loctite® BLACK Maxx Silicone**
- **Loctite® Superflex® RED High Temp RTV**

**4 GENERAL CLEANER**

- **Loctite® Brake & Parts Cleaner**
- **Loctite® Throttle Body & Combustion Cleaner**
- **Loctite® Eva Disinfect Spray** - for Air Conditioning system

**5 UNDERBODY COATING**

- **Teroson RB R2000 HS** - Highly Abrasion Resistant, Road Stone Anti-Chip, Sound Damping

**tesa**®

## Adhesive Tapes for Electronics

### Adhesive Tapes and Die-cuts



tesa® tapes has been supporting the electronics industry, including Smart Phones and Digital Cameras production, by offering special solutions that meet their sophisticated and ever-changing technology.

### Heat Activated Film

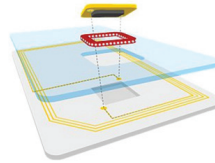

From Chip Bonding to Card Attachment – we offer reliable adhesive solutions for the smart card industry.

### Masking Tapes

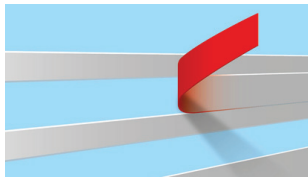

Are essential for painting and provide perfect, sharp edges. Easy to use and with residue free removability even from delicate surfaces, both indoors and outdoors.

### Specialty Masking Tapes



Supports delicate and high temperature processes such as Belting of electronic components.

Also covers a wide range of different applications, such as masking, surface protection, floor marking, and painting, for aviation, rail, and marine industries.

### Security Packaging Tapes



Security tapes offer unique functions and can be combined in various ways to provide tamper-evident packaging and help protect parcels from theft and unauthorised opening.

### Strapping and Filament Tapes



A strong and tear resistant tesa's range of Filament and Strapping Tapes for bundling, palletising and end tabbing, securing and fixing.



## PURIFICATION PRODUCTS

HIGH-END



## CLEANROOM SOLUTIONS

- Manufactured and packed in cleanroom class 10/100 environment.
- Ultra-low lint and contamination level
- With cut edges of normal-cut, Ultrasonic-sealed and Heat-sealed edges.
- Manufactured in ISO factories with in-house laboratory
- Critical specification and full test reports.
- Typical applications: Electronics industries - critical cleanroom class 10/100 environment • Optical & display industries - cleaning lens and sensitive surfaces • Automobile industries • Jewellery industries.



### Microfiber Wipes Type: EX- Cloth

- 70% Polyester; 30% Nylon
- No silicon oil, Amide or DOP detected
- Dimension: 4"x4"; 6"x6"; 9"x9"
- Weight: 165 g/m2



### Microfiber Wipes Type: MX- Cloth

- 70% Polyester; 30% Nylon
- No silicon oil, Amide or DOP detected
- Dimension: 4"x4"; 6"x6"; 9"x9"
- Weight: 80 g/m2



### Polyester Wipes Type: UltraPoly-L Class 100

- 100% Polyester
- Silicone Free
- Dimension: 4"x4"; 6"x6"; 9"x9"
- Weight: 125 g/m2



### Polyester Wipes Type: UltraPoly-H Class 100

- 100% Polyester
- Silicone Free
- Dimension: 4"x4"; 6"x6"; 9"x9"
- Weight: 145 g/m2



### Cleanroom Class 100 Facemask

- Basic material: Polyester and Nylon
- Silicone Free. Ultra-low lint.
- Solvent-safe double bag cleanroom packaging.



### Cleanroom Class 100 Gloves

- Types: Latex or Power-free Nitrile Gloves
- Size = S, M, L
- Length = 12 inches
- 50 pairs per bag; 10 bags per carton.



# Industrial Coating System

Whether you are coating tractors, forklifts, machinery, trailers, steel structures, cars, tanks, or coating aluminium, timber, plastics surfaces, etc, the versatility of the Nason® Industrial product range will successfully meet the need.

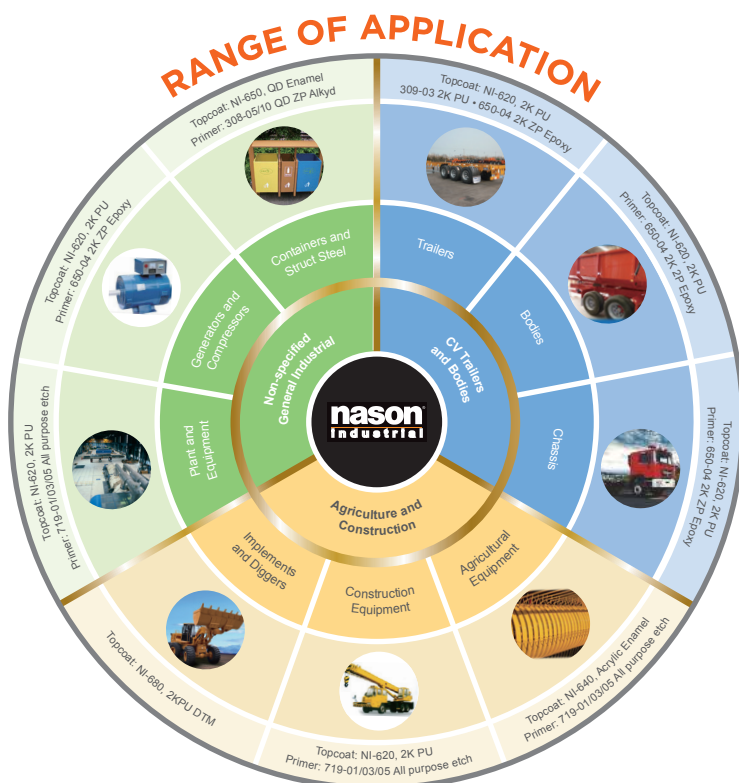

## Paint Products



### NI-100C 2K DTM Primer

- A ready to use 3 in 1: Primer, Basecoat and Topcoat.
- Excellent water & chemical resistance.
- Isocyanate-free, suitable for in-situ maintenance.



### NI-620 Standard 2K PU Topcoat

- 2 pack (2K) high gloss, isocyanate cured polyurethane topcoat.
- Good weathering and good anti-corrosion properties.

## Non-Paint Products



### AUDURRA DRY SANDING PAPERS

- More productive and competitive in price in its segment (mid to premium)
- Re-usable by soaking overnight. Technically will be 1 level less.

An Axalta Coating Systems Brand

# Hunter

## Tools and Equipment

### LEAD FREE SOLDERING STATION



#### Hunter 301 ESD Soldering Station

- Excellent Heat Recovery from room temperature to 500°C within 5 sec.
- Temperature Locked by Password
- Easy replacement on iron tips without changing Sensors.



#### Hunter 203H ESD Soldering Station

- Excellent Heat Recovery
- Temperature Locked by Password
- Easy replacement on iron tips without changing Sensors.



#### Hunter 967 / 969 ESD Soldering Station

- Compact in Size, Light Weight
- For gentle soldering purposes
- Analog / Digital Display Mode

### Replacement Tip Hunter ESD Soldering Station

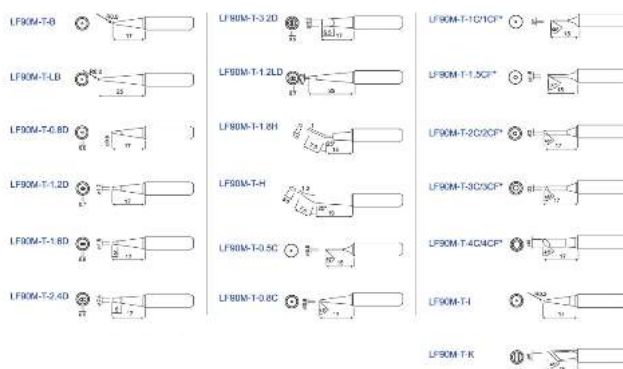
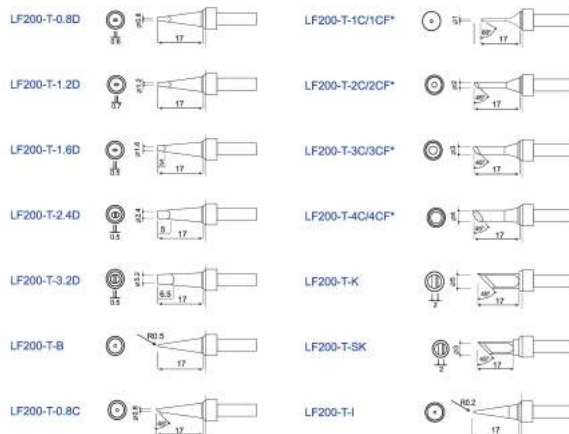
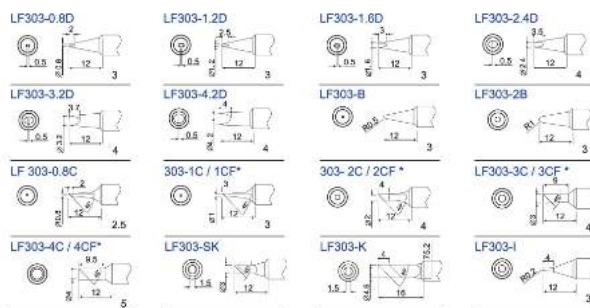



## Thermal Transfer Ribbons

DNP Ribbon offers most critical print quality for thermal transfer's variety of applications including shipping, logistic, inventory, horticulture, shelf, retail, pharmaceutical, food & beverage, parts packaging in automotive, product ID, retail, RFID, Signage, etc.



### DSW Wax

- Smudge resistant
- Printhead protection.
- High-speed. High-density.



### Signature Series™ Wax

- SmoothCoat® backcoat
- Unbeatable edge definition for dark, dense images and improved scan rates

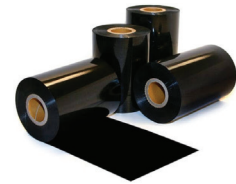

### TR4085plus® Wax

- SmoothCoat® backcoat
- Smudge resistant & scratch resistant
- Halogen-free. Anti-static. High-speed.



### R300 General Purpose Resin

- Anti-static. High-speed.
- Abrasion and solvent resistance
- Printhead protection.



### TR6075 All Purpose Resin

- Solvent resistance
- Extensive label adaptability
- Anti-static. High-speed.
- CSA approved.



### DSM Wax/Resin

- SmoothCoat® backcoat
- Anti-static. High-speed.
- Superior print quality on low-end synthetics.



### TR6080plus Premium Performance Wax/Resin

- Abrasion resistant and solvent resistant.
- Halogen-free. High-speed.
- Unbeatable edge definition for dark, dense images and improved scan rates.

# SIEMENS Digital Factory

**Comprehensive offering for greater efficiency through automation technology**  
Discover how Integrated Automation Systems boost your competitive edge, reduce downtime, and improve your profit and productivity.



## **SIMATIC: Integrated and Efficient**

The SIMATIC range of controllers comprises of Basic, Advanced, Distributed and Software Controllers offering impressive scalability and integration of their functions. The engineering in the Totally Integrated Automation Portal (TIA Portal) enables optimum automation solutions to be found for every application.

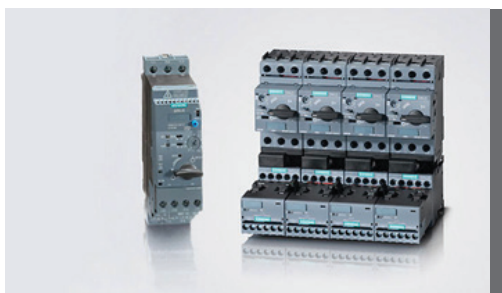

## **SIRIUS - Industrial Controls**

With SIRIUS, we offer you a unique comprehensive portfolio for every industrial control application. With the new SIRIUS system configurator you can save up to 80 per cent of the time required for product selection and configuration.

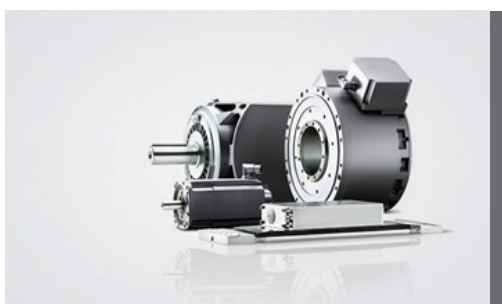

## **SIMOTICS: Motors for Motion Controls**

Every motor for motion control is characterized by compact design and high operating efficiency. With a wide range of performance classes and installation sizes, our product range has the right motor for your motion control application, too.



## **SINAMICS: The Right Drive, All The Time**

Drives to fulfil requirement of frequency converters in all application areas. Our SINAMICS portfolio represents uniform engineering, extremely high efficiency and convenient operation.

# GENERAL PRODUCTS

We know the importance of selling multiple products to fulfil our customer's needs. That is why we are committed to also provide you all solutions you need apart from our main products (Authorised Partners).

## Cleanroom Products

Jumpsuit, smocks, sticky mats, sticky rollers, bouffant and mob caps, shoe covers, face masks, cleanroom wipers.

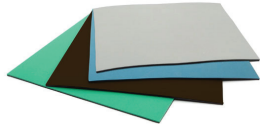

## ESD Products

ESD mats, tweezers, ESD accessories (adjustable elastic wrist-ban)  
**ESD Gloves:** Lint Free Gloves, Top/Palm Fit Gloves.



## Disposable Gloves

Class 100 Cleanroom Gloves:  
Pre-powdered Latex Gloves,  
Powder Free Nitrile Gloves,  
Powder Free Vynil Gloves.



## Finger Cot

We manufactured our own finger cots, vacuum packed in clean-room environment.



## Tools & Equipment

Caliper, Microscopes, Weighing Machines, Work Light, Ring Illuminator, etc.



## ESD & Cleanroom Packaging

Class 100 Nylon/PE Bag,  
Anti-static Air Bubble Bag,  
Tyvek Moisture Barrier Bag,  
Silica Gels.



## Industrial Chemicals

A green/sustainable solution by minimising the use and generation of hazardous substances of chemicals. It provides **Total Package Solution** that can solve all your non-compliance issue.

Products: Aqueous base cleaner, remover, degreaser of ferrous & non-ferrous materials  
Typical uses: Printed Circuit Board Industries, Metal Stamping/Precision Engineering Industries.

**KNIGHTCLEAN**





# OUR TEAM



## Technical Engineer

We are not only selling the right solution for you. We make sure our customer get the most support from us through product knowledge transfer, maintenance and installation.



## Warehouse

(bonded & local warehouse)

We keep our stock in a very spacious warehouse under warehouse management that maintains storage of our products and delivers them in the best condition.



## Delivery Team

It is our top priority to make sure our loyal customers gets what they need faster without any hassle.



## Customer Service

We always tried to be the best listener for our customers. We make sure every customer's requirements are met.

[www.ekasurya.co.id](http://www.ekasurya.co.id)



**PT EKASURYA INOUT INDONESIA**

Kawasan Industri Delta Silicon 3  
Jl. Sungkai Blok F26 No. 10  
Lippo Cikarang, Bekasi 17530, Indonesia  
Ph/Fax: +62 21 8990 6301-03 / 89906118  
email: [eii.marketing@ekasurya.co.id](mailto:eii.marketing@ekasurya.co.id)

**PT EKASURYA INTERNUSA INDONESIA**

Jl. Raya Kalirungkut No.5  
Ruko Rungkut Megah raya Blok J-35  
Surabaya 60293, Jawa Timur, Indonesia  
Ph: +62 828 9409 8899 / 828 9409 7755  
[www.ekasuryainternusa.com](http://www.ekasuryainternusa.com)