

24kV/36kV Metal-Enclosed
SF₆ Gas Insulated Switchgear

MEIDEN

HICLAD 20GB/HICLAD 30GB



Empower for new days

Compact, reliable, and economic for medium-voltage applications

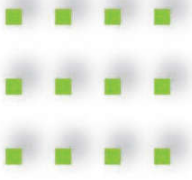

Design Concept

This switchgear conforms to IEC62271-200, and all primary components employed therein are in accordance with the relevant IEC standards. It is designed to accommodate high-performance vacuum circuit-breaker (VCB), which has been designed and tested in accordance with IEC62271-100. SF₆ gas insulation used in conjunction with VCB has resulted in switchgear setting new standards with respect to;



- Operation reliability
- Reduced maintenance work
- Safety for persons
- Free from environmental pollution
- Reduced dimensions and less space requirements
- Current interruption by VCB with zero SF₆ gas pressure (equal to atmospheric pressure)

Features

- **Safety**
No exposure of high-voltage live part to the air.
Complete interlocking system against erroneous operation.
Equipment of manual operation mechanism in an emergency.
- **User-friendly**
Visualized operation mechanisms equipped with mimic bus and symbols.
All switching devices can be operated from remote.
Compact size achieved by optimal arrangement of devices.
- **Imperious to environment**
High-voltage live part is completely protected against moisture and dust.
- **Reliability**
Reliable gas-insulated busbar system.
Keeping the ability of breaking circuit, even if the insulating gas pressure becomes zero.
Enhancement of reliability by reduction in number of parts achieved by simple structure.
- **Adaptability**
Adaptable for various requirements of network by employing plug-in type voltage transformer and lightning arrester.
Insulating performance is imperious to the installation altitude.
Test of high-voltage part can be fully performed without any gas handling.
- **Economical Efficiency**
Easy maintenance.
No maintenance is needed for high-voltage equipment in the gas compartment.
SF₆ gas is not polluted by arc because of employing VCB.
(SF₆ gas is used only as insulation medium.)



24kV/36kV

Technical Specification

Technical data

Table 1 Switchgear

Switchgear model	HICLAD 20GB	HICLAD 30GB
Switchgear type	NBG-24	BGB-36
Applicable standards	IEC62271-200	
Classification of switchgear	SF ₆ -insulated metal-enclosed	
Service condition	<ul style="list-style-type: none"> • Altitude < 1000m • Ambient temperature Max. 40°C, Min. -5°C 24h, average < 35°C • Relative humidity 24h, average < 95% 1 month average < 90% 	
Rated voltage (kV)	24	36
Rated current (A)	1250, 2000	1250, 2000, 2500
Rated frequency (Hz)	50/60	
Insulation level	<ul style="list-style-type: none"> 1 min power frequency (kV rms) 1.2 x 50 μs impulse (kV peak) 	
Rated short-time withstand current (kA-s)	50	70
	125	170
	25-3	31.5-3
Degree of protection	IP65	
	IP40	
Gas pressure	<ul style="list-style-type: none"> Rated pressure (MPa) 0.05 Alarm pressure (MPa) 0.02 	
Operation of 3-position isolator	Motorized / Manual	
Auxiliary voltage	<ul style="list-style-type: none"> Control circuit (V) DC 30, 110, 125, 220 Motor circuit (V) AC 220, 230, 240 / DC 110, 125 	

Table 2 Vacuum Circuit-Breaker (VCB)

VCB model	NVG-22	VGB-33
Applicable standards	IEC62271-100	
Rated voltage (kV)	24	36
Rated current (A)	1250, 2000	1250, 2000, 2500
Rated frequency (Hz)	50/60	
Insulation level	<ul style="list-style-type: none"> 1 min power frequency (kV rms) 1.2 x 50 μs impulse (kV peak) 	
Rated short-circuit breaking current (kA)	50	70
	125	170
Rated short-circuit making current (kA peak)	25	31.5
Rated short-time withstand current (kA-s)	63	82
	25-3	31.5-3
Operating duty*	O-0.3sec-CO-3min-CO	
Rated closing time (s)	0.05	
Rated opening time (s)	0.05	
Rated break time (s)	0.07	
Rated TRV for terminal fault	<ul style="list-style-type: none"> Rate of rise (kV/μs) 0.47 TRV peak voltage (kV) 41 	
Type of operating mechanism	Motor charged spring	

* : Other duties, O-0.3sec-CO-1.5sec-CO, O-0.3sec-CO-1min-CO-1min-CO are also available.

Construction

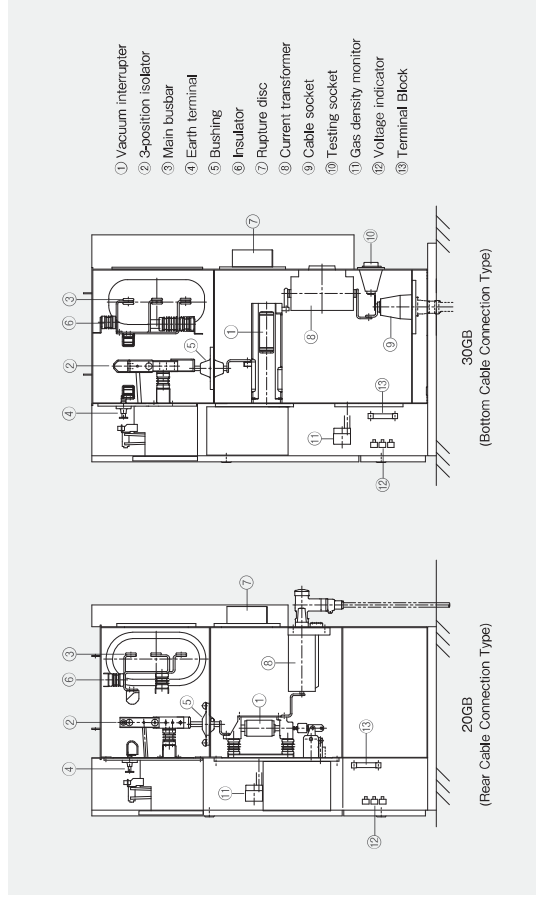

Gas monitoring system

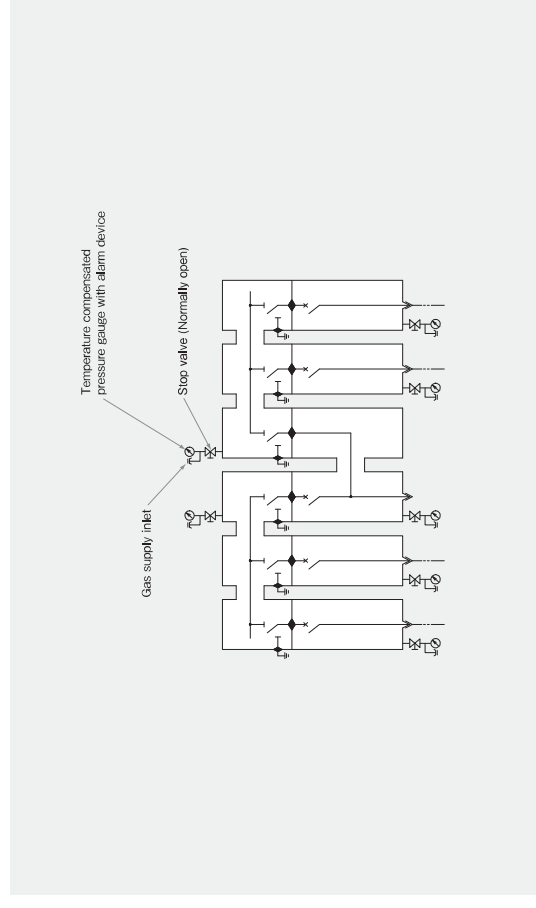

Basic Pattern (Rear Cable Connection Type)

Feeder panel

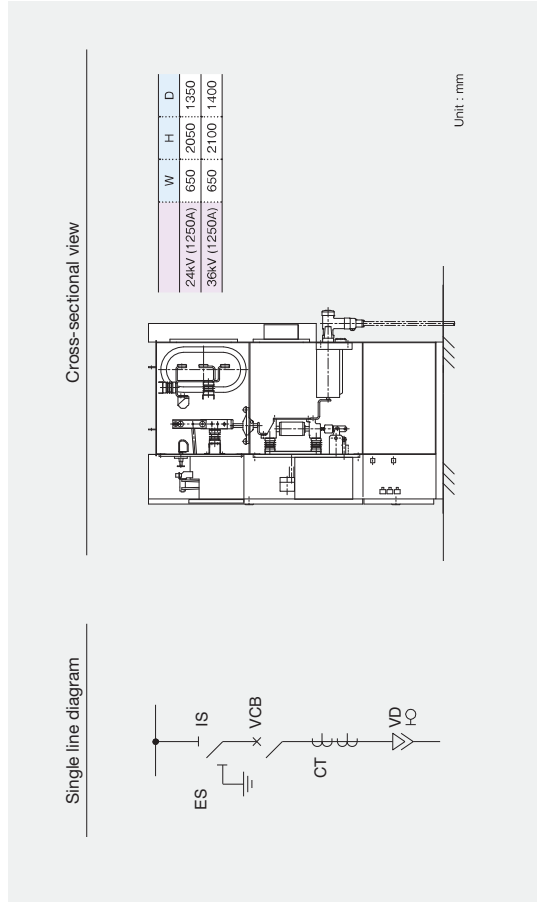

Feeder panel with VT

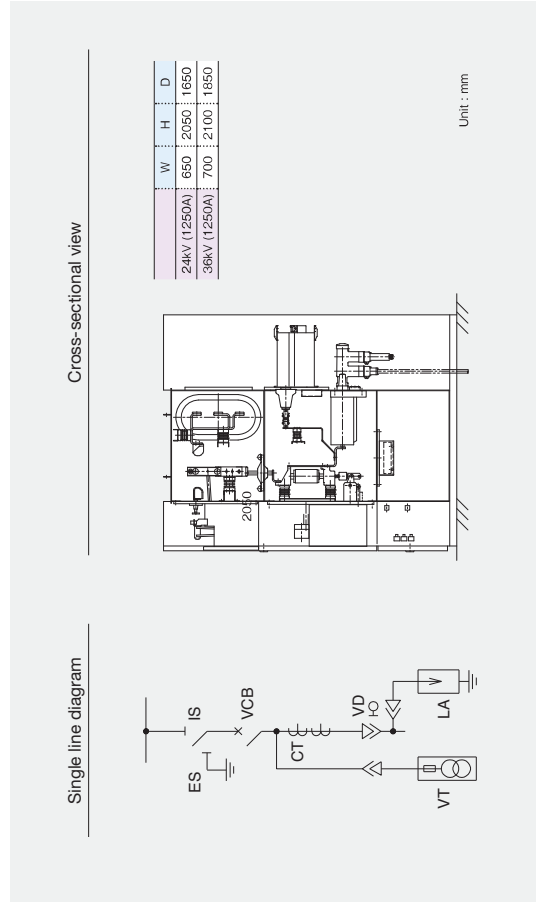

Note: Dimensions and components may be changed according to the specifications.

Bus section panel

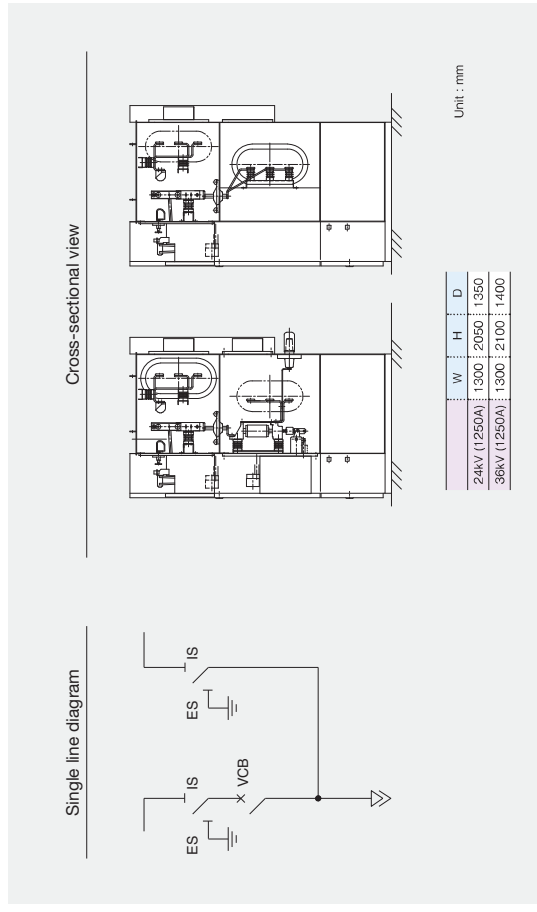

Bus section panel with CT & Bus VT

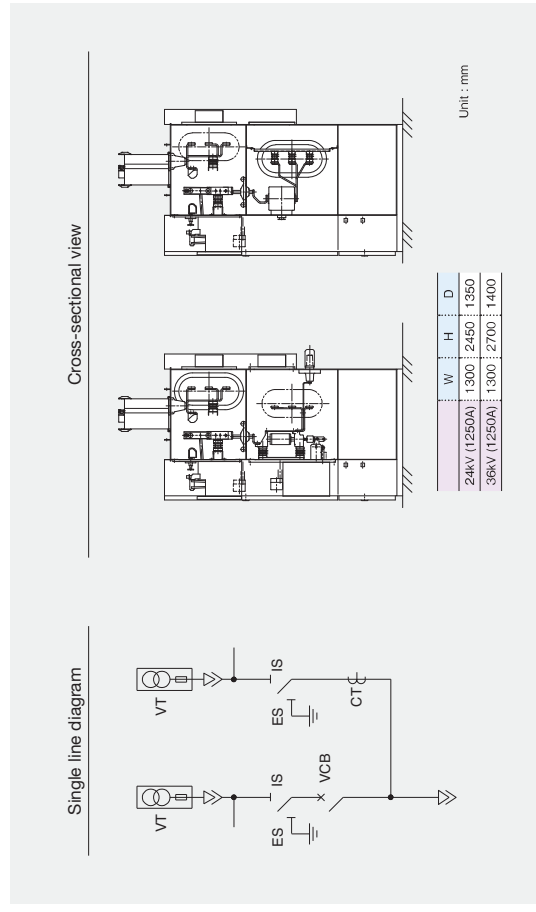

Note: Dimensions and components may be changed according to the specifications.

Basic Pattern (Bottom Cable Connection Type)

Feeder panel

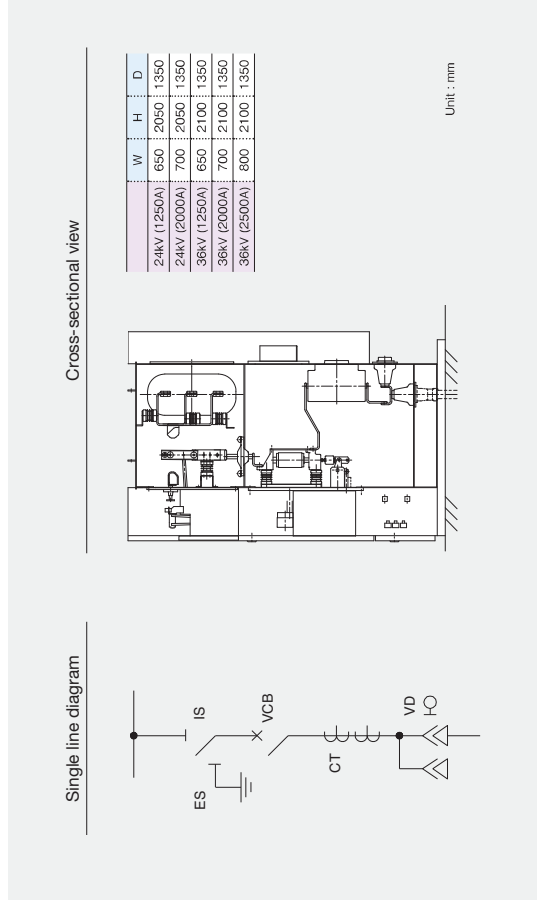

Feeder panel with VT

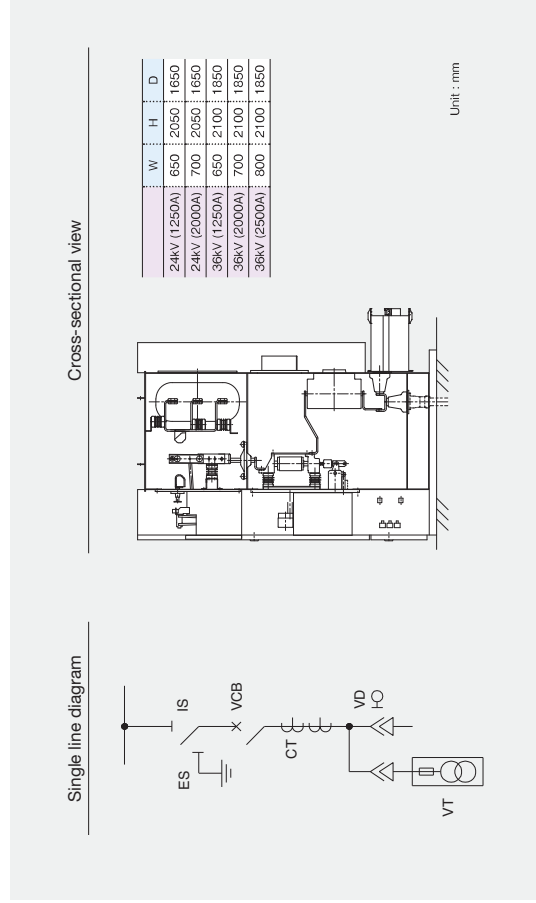

Note: Dimensions and components may be changed according to the specifications.

Bus section panel

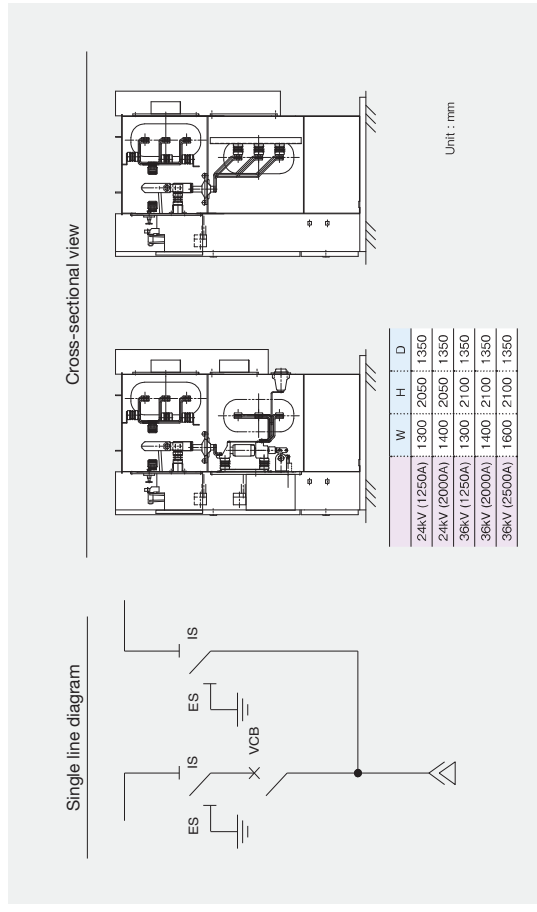

Bus section panel with CT & Bus VT

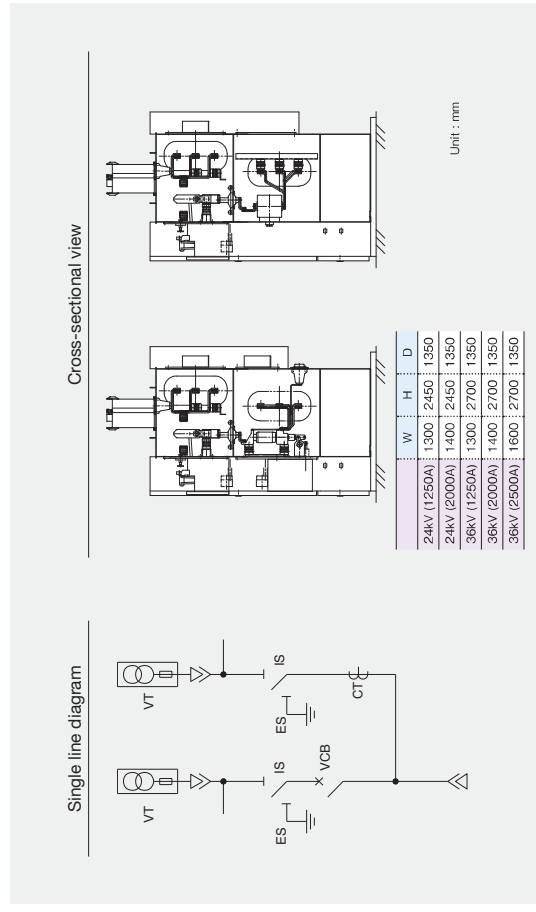

Note: Dimensions and components may be changed according to the specifications.

Installation

The individual switchgear, which has been assembled, wired up and tested in factory are delivered to site. Site works for installation require only the setting of the switchgear in the position, connections of inter-panel joints of busbars and cabings of both power and control cables. The typical maintenance space, dimensions of cable pit and foundation are shown in Fig.2 and Fig.4 respectively.

Fig.1 Single line diagram

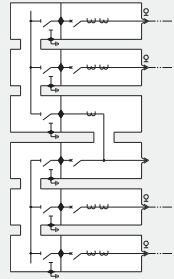

Fig.2 Maintenance Space

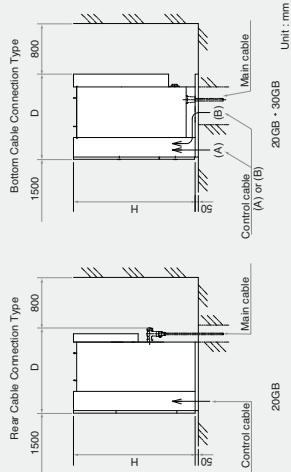

Fig.3 Switchgear Alignment

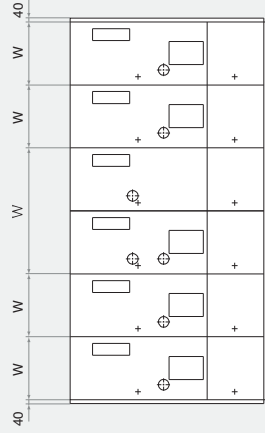
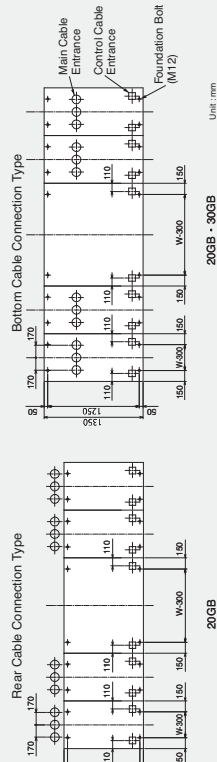

Fig.4 Foundation



Note: The opening size of cable pit and the location of foundation bolt should be confirmed on each project.

Cable Termination and Testing

HICLAD 20GB/30GB employs high reliable cable termination system, which is of pre-molded plug-in type for various types of 24/36kV power cables.

The cable plug can be equipped with capacitive voltage diverter to connect with the neon voltage indication lamps for continuous voltage monitoring of main circuit. And also it allows phase sequence check by portable phase comparator after connection of cables. In addition, high voltage test plug is available to perform both primary injection test for CTs and high voltage test for cables connected to switchgear.

Typical arrangement of cable termination system and high voltage test plug are shown in Fig.5. The following tools / accessories are optionally available to the cable termination system.

1. High voltage test plug / adapter for primary injection test and high voltage test
2. Protection cap for protecting withdrawn cable connectors against damage and dirt
3. Blind cap for protection against electric-shock hazard for live cable connector
4. Dummy plug / Sealing end for sealing and voltage-proof closing of plug-in socket
5. Phase comparator for phase sequence check
6. 3-phases earthing and short-circuit device / Earthing adapter for earthing and short-circuit of cable circuit of switchgear

Fig.5 HV Test Plug

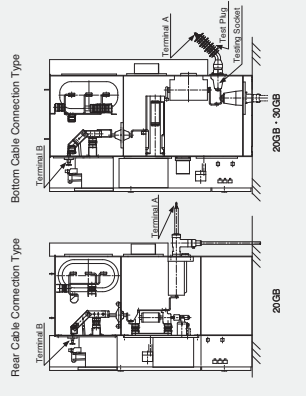

The earthing of main busbar and line side shall be performed as shown as in Fig.6.

Fig.6 Earthing

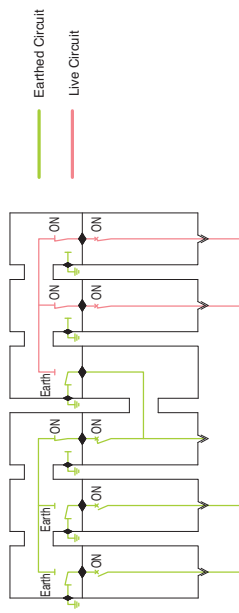

Ancillary Equipment

HICLAD 20GB/30GB provides the following ancillary equipment.

1. Mechanical indicators
 - a. Operating counter of circuit breaker
 - b. Spring, "Charged-Discharged"
 - c. Circuit breaker "ON"
 - d. Circuit breaker "OFF"
 - e. 3-position isolator "ON"
 - f. 3-position isolator "OFF"
2. Padlocking facilities (Option)
 - a. Front door of LV compartment
 - b. Manual "ON" and "OFF" push button switches of circuit breaker
 - c. Inlet for manual operating handle of 3-position isolator