

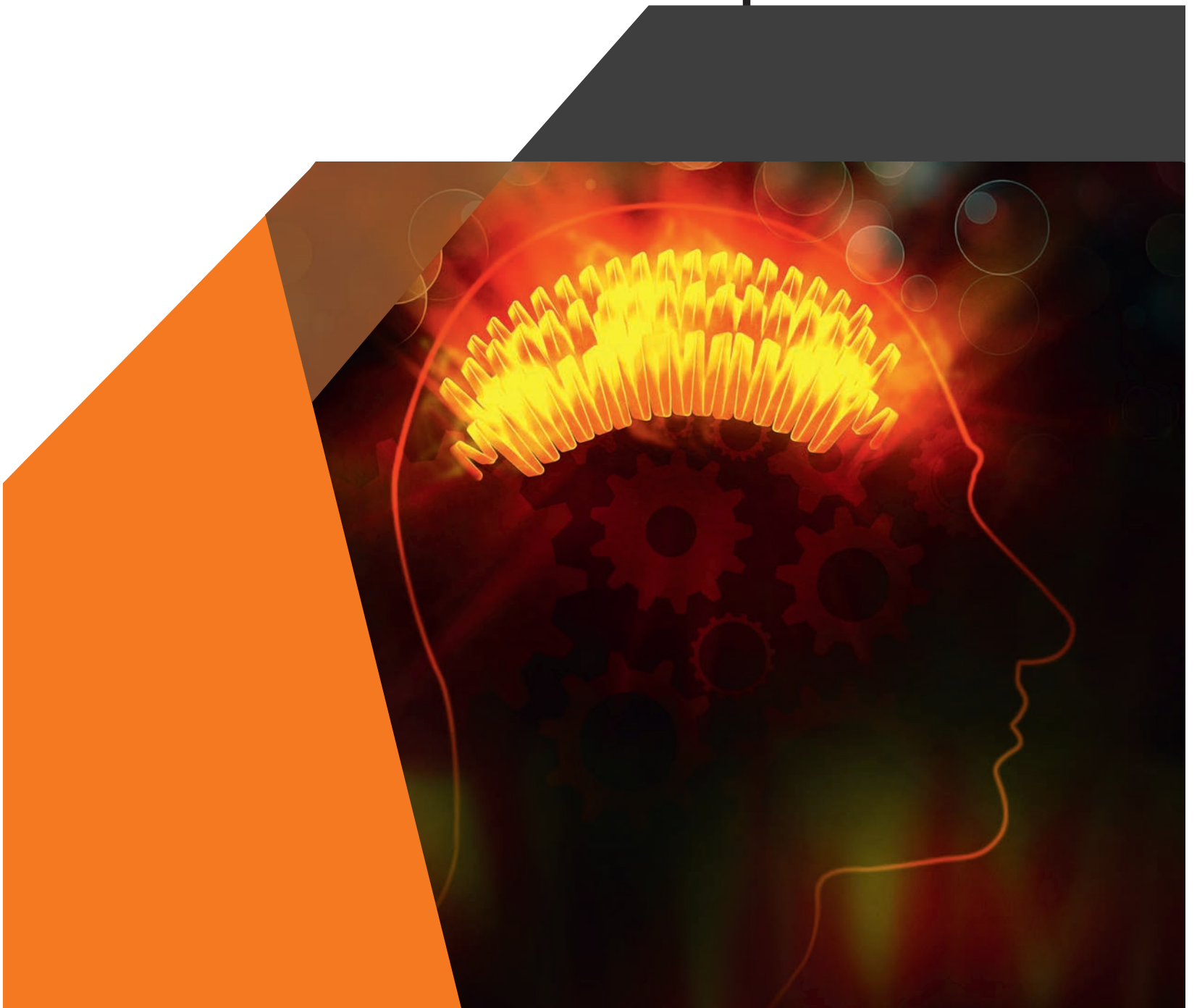

Our **HEAT**
is your
Improvement



Company Profile

Prolific Heating International Co., Ltd is an established player in Heating Equipment Industry. We serve multiple industries for the heating related equipment through our versatile products and services which include design, manufacture, installation and maintenance of industrial heaters or heating equipment such as:

- Heat-resistant wire
- Silicon Carbide Heater
- Molybdenum Disilicide Heater
- Graphite Heater
- Industrial Furnace & Oven
- Heating Insulation
- Thermocouple & Controller
- Mesh belt

And other furnace component and accessories, services for multiple industries such as:

- Heat Treatment Industry
- Automotive Industry
- Electronics Industry
- Steel Industry
- Foundry Industry
- Non Ferrous Industry (Aluminium Industry)
- Glass, Porcelain, Ceramics Industry and Advanced Materials Industry
- Science and Technical Industry
- Medical and Pharmaceutical Industry
- Precious Stone & Metal Industry (Jewellery Industry)
- HVAC Industry
- Science and Technical Industry
- Additive Manufacturing Industry

Founded	20 July 2005
Address	11/11 Moo 11, Soi Kingkaew 37, Kingkaew Rd., Rachathava, Bangplee, Samutprakarn Thailand. 10540
Employee	72 (2019) People
Company Slogan	Our Heat is Your Improvement
Country Served	Thailand, Vietnam, Indonesia, Malaysia, Singapore, Laos and other ASEAN Countries
Language	Thai, English, Japanese, Bahasa Indonesia, Bahasa Malay, Vietnamese, and Mandarin



The management team includes;

- | | |
|--------------------------------|------------------------------------|
| 1. Mr. Phummarin Sorsrisakorn | Managing Director |
| 2. Mr. Chaipot Maksuk | Management Advisor |
| 3. Ms. Kulprapa Kanokchaisakul | General Manager |
| 4. Mr. Saran Kingkeaw | General Manager |
| 5. Mr. Edmund Lim | Technical Advisor |
| 6. Mr. Takahiro Yoshioka | Marketing Manager |
| 7. Mr. Yoshiki Saito | Sales Manager |
| 8. Ms. Merry Puritanita | Regional Sales & Marketing Manager |

Message from the Managing Director

“Our Heat is Your Improvement”

Prolific Heating International Co., was built with passion to give solution based products and services to customers in Heat Treatment and other wide variety of heating industry. Under the slogan “Our Heat is Your Improvement” we strive to provide reliable and high quality product & service. We are aiming to carry out business with honesty, integrity, moral and ethical. Our company been has continuously expanding from heater making, furnace maintenance, overhaul, new furnace design, brand agency of well-known Furnace & its accessories; in accordance with our business model with concept of Innovation, Efficiency, Effectivity, Availability & Reliability. Not only overlooking domestic Thailand Market but we also have a vision as the supplier & solution giver for other ASEAN Countries such as Indonesia, Vietnam, Malaysia, Singapore, Laos, Philippines, etc.

Close to Market, and Close to Customer

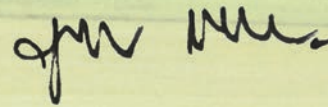

Phummarin Sorsrisakorn
Managing Director



Business Model

Through product realization process, we conduct our business according to models and philosophies as follow ;



Obligation

We provide feasible products and services, fulfilling our commitment of quality, at reasonably delivered price.



Availability

Stock availability is a key success in providing our product and service timely.



Optimization

Optimized combination of quality, cost, efficiency and environmental minded are included in our product realization process.



Innovation

Research and Development are our principle to innovative advanced products and services.

Heating Technology Solutions



Enquiry Review



Engineering Design
and Development



Procurement



Manufacturing
Services Spare
Parts Providing



Logistics

“Our Heat is Your Improvement”

Through realization process, we manage our business as following business flow.

Resistance Heating Alloys for Appliances and Heaters



There are two types of Metallic heat resistant alloys :

Ferritic iron chromium aluminium alloy and Austenitic nickel chromium iron alloy. The difference is crystal structure and physical, mechanical, electrical, and thermal properties.

Our various industrial heaters (approximated range temperature 60°C – 550°C) which are designed under your requirements, manufactured by our capable process, to assure the reliability and the responsiveness, the verification of products before delivery on committed time.



Industrial Heaters

Service Temperature 80 °c - 550 °c

Tubular Heater

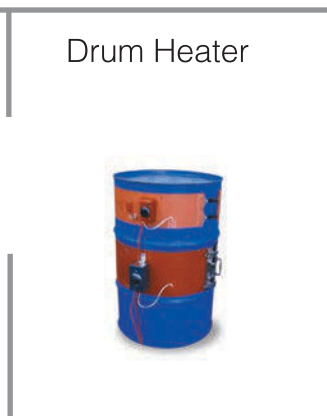
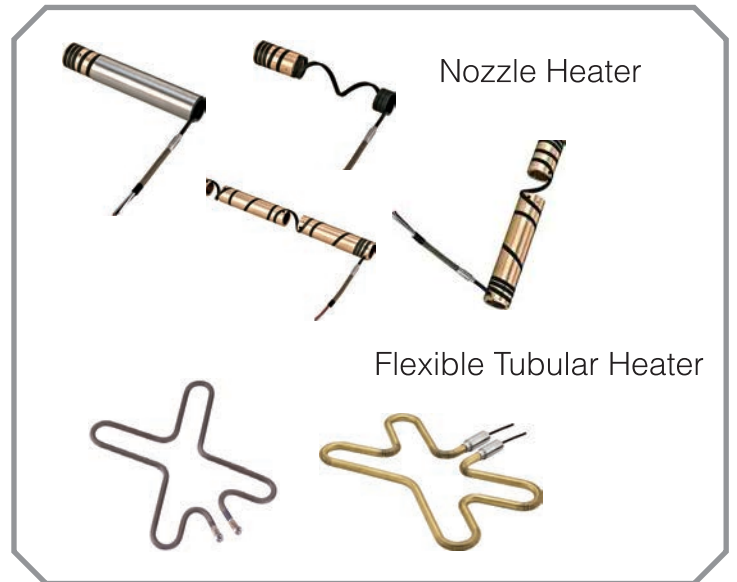

Resistance Wire & Strips (Up to 1400 °c)

As a manufacturer of heating components, we design and produce weater from resistive alloys effectively & efficiently. We carefully select the proper resistance based on the operating temperature and environment which it will be exposed to. Whether you are looking for wire or strip heating element, Prolific Group have what you are looking for. Our products will meet your low or high temperature applications.

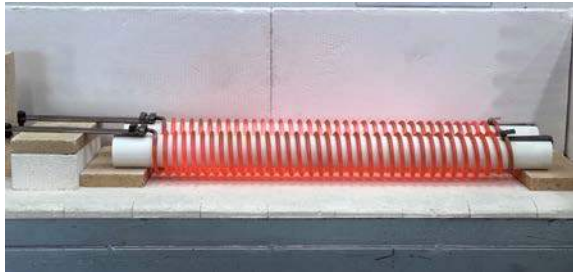

Heat Testing Process



Applications:

Industrial ovens and furnaces for aging, annealing, brazing, hardening, carburizing, annealing, heat treating, holding, melting, muffle, heated injection machine pit, plastic injection molding, dies casting machines, powder coating, or sintering



Characteristic:

- Continuous operating temperature up to 1400C
- Voltage: 220 volts / 380 volts
- Quick heat up time & easily replaceable
- Easily configured to furnace chamber
- Wide temperature range
- Varied available sizes
- Engineered to fit your furnace refractory

Wire Stock Classifications:

FCHW-1	A-1	PX-D
FCHW-2	AF	PX-DS
NCHW1	APM	PX-N1

Radiant Heater or Bundled Rod and Radiant Tube (Maximum Temperature up to 1300 °c)



Radiant Heater for Aluminum Industry



Radiant Heater & Protection Tube (RTH)



The electric radiant tube heater consists of heat-resistant alloy tube in which heating element are attached. It is used for gas carburizing and also suitable for ceramic fiber lined furnaces and general purpose furnace due to ease of installation and replacement.

Application : Air, Exothermic gas, NX gas, Carburizing and Batch type furnace

Installation : Longitudinal and lateral directions

Material of radiant tube : SUS310s, Centrifugal casting tube, SiSiC tube, etc.



Inspection & quality control checking

Innovation Heater Design up to 1400 °c



Prolific Heating International Co., Ltd.

cooperates with Kerfa® to serve the industry of industrial furnaces and appliances with an extensive range of innovative system solutions. As one of the well-known German Company, Kerfa® produces efficient and long-lasting electric resistive heating elements as well as efficient heating and environmentally friendly insulating systems containing vacuum-formed ceramic or bio fibers.



Customer benefits:

High plant availability by quick

- Temperature adjustments:
- High energy efficiency:
- Long system service life:
- Lower maintenance requirements:
- Reduced storage cost by flexible production **at Kerfa**

- Reduced operating costs
- Reduced operating costs
- Lower investment costs
- Reduced operating costs
- Reduced operating costs

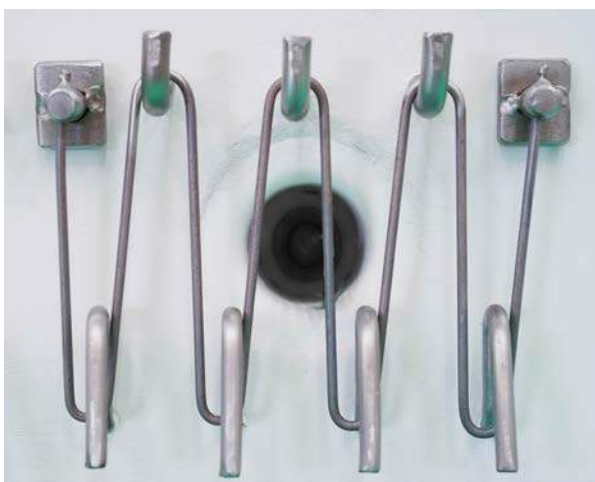

Fields of application

- Industrial furnaces
- Laboratory furnaces
- Melting and holding furnaces for non-ferrous metals
- Thermal treatment facilities
- Protective gas generators
- Heating equipment and apparatus

Products

- Vacuum-formed Kerfa® SAVAC® insulating systems for gas-fired and electrically heated furnaces
- Electric Kerfa® SAVAC® heating systems, embedded or suspended
- Custom solutions available in complex forms, too

Temperature Ranges

Kerfa® SAVAC® insulating systems:
Max. 1.600°C

Kerfa® heating elements:
Max. 1.400°C

Molybdenum Heater up to 1450 °c



Prolific is a distributor of A.L.M.T. for hyper material products. Our supplier is a top manufacturer having processing technologies of tungsten and molybdenum metal products.

We can comply with various processing request by our special materials and full line-up of production.

We can provide information of usage and cooperation in designing and full line-up production for special process that meets each customer's needs based on the considerable experience we have accumulated in tungsten and molybdenum processing.

Additionally, we supply high quality, substantial evaluation, analytical instruments, and know how.

Molybdenum wires and rods

Product selection guide

Application	Non-sag	Quakeproof	Machinability	Wear resistance
MOP Structural materials, Heaters, Bolts, Nuts	△	○	◎	◎
MOS Grids, Mandrels, Anchors	○	○	◎	○
TEM Supports, Heaters, Bolts, Nuts, and Supporting shafts for X-ray tubes	◎	◎	◎	○
DM Heaters, Support	◎	◎	○	◎

Legend: ◎ Most suitable, ○ Suitable, △ Unsuitable

Examples of use in vacuum (1×10^{-5} Pa) at 1500°C

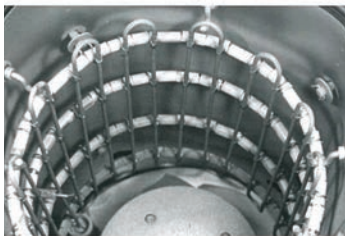

TEM heater used for 3 years

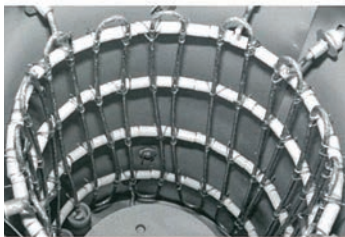

Pure Mo heater used for 1.5 years



High temperature furnace parts in special-purpose products of tungsten and molybdenum

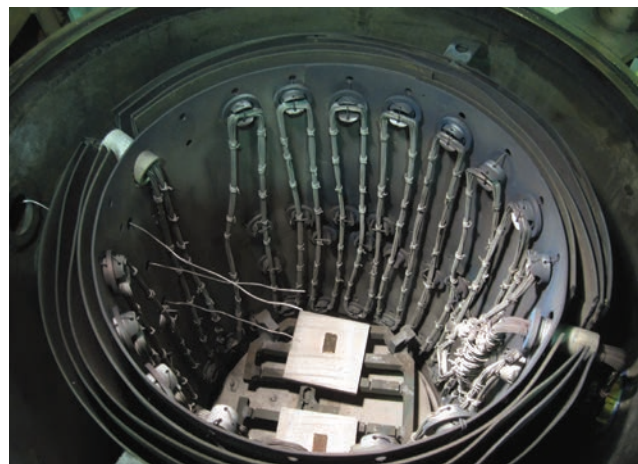
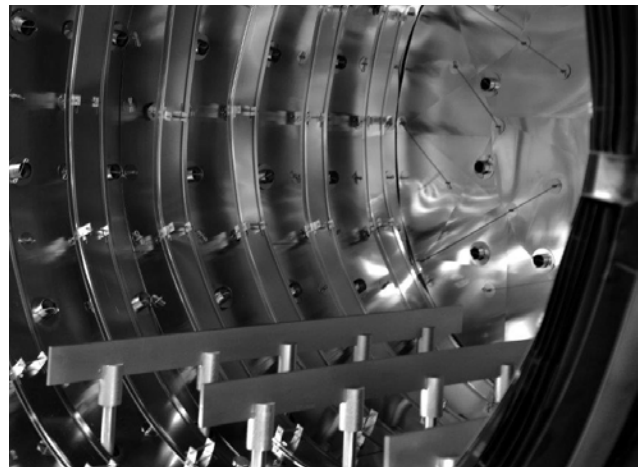

High Temperature 1650 °c

SiC Heating Element "EREMA / Japan"

EREMA



EREMA focused on "Energy Saving", "Environmentally Friendly", "High Temperature" and "High Quality" results.

Erema's electric heating elements, composed of recrystallized high-purity silicon carbide, were the first of their kind to be introduced into the market in Japan.

EREMA, produced by Tokai Konetsu Kogyo Co., Ltd electric heating elements have earned a reputation as being high quality products, as well as the world's largest production scale with enhanced and upgraded quality since they were introduced to the market in 1927.

Produced using the finest raw materials, advanced technology and superior quality. EREMA products have pioneered many advanced applications in high temperature and heating technology.



EREMA SiC Heater Up to 1650 °c



Immersion Heater (Under Heater)



Prolific Heating International Co., Ltd. facility, assembling Immersion Heater with highest standards and craftsmanship.

Progressing in industry's acceptance, also, is becoming more commonly and widely used, designed to be useful in melting or holding furnaces. Immersion Heater provides advantages of energy saving and easy installation.

Type-U



Type-SGR



Type-W



Type-W-D6

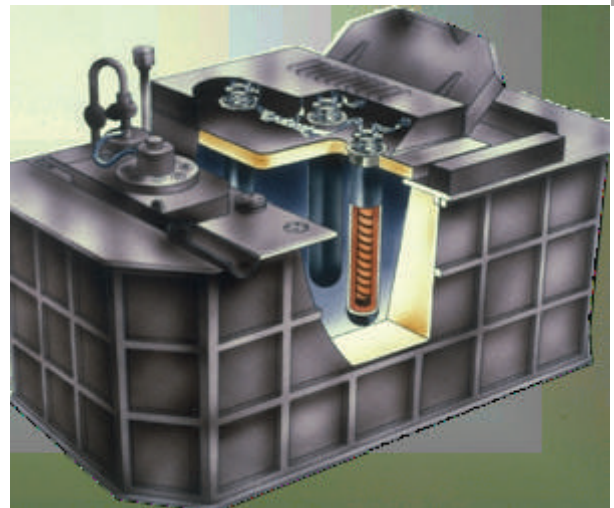

SGR Type Assembled with Silicon Nitride Tube

MoSi2 Heating Elements



Max. Temperature 1850 °c
WINNER DELUXE 1700 & PRIMA 1850



Cylindrical Type

We are the distributor of various type of high temperature heaters and components such as heat resistance wires (up to 1400*c), Silicon Carbide Heaters (Sic, up to 1600*c) and Molybdenum Disilicide Heating element (MoSi2, up to 1850*c) both for standard and customized products. It can be used in wide range of industries.

In addition, we can also design and codesign with our customers to maximize effectiveness and efficiency of our products as well as to meet our customers expectation.

Cooperating with heating element maker Winner which producing high quality heater with very high efficiency, it is appropriate to industrial furnace, glass melting furnace, incinerators, and experimental furnace for R & D.

As electric heating element, do not produce harmful gases, thus being a worthy environmentally friendly product.



MoSi2 Heater Bending 90°c



MoSi2 Heater U-Shape

Graphite & Carbon Fiber-reinforced Carbon (CFC) Materials



Graphite as the stable modification of carbon with hexagonal crystal lattice made from superimposed flat carbon layers thus graphite offers excellent thermal and electrical conductivity. Its mechanical strength increases greatly with a rising temperature up to about 2500 degree Celsius.

Meanwhile for CFC: carbon is greatly reinforced by carbon fibre that creates highly stable material resistant and break-proof, lightweight, rigid and thermally stable). Typical application temperature of CF are between 1000 and 2000 Degree Celsius. The creation of the CFC was driven by the material requirements for aerospace engineering, thus this material has been tested and proven for it's quality.

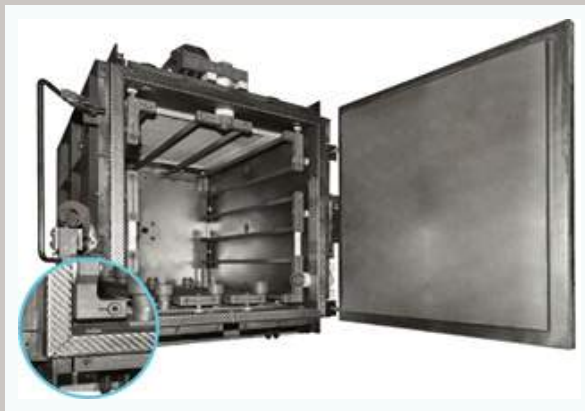

Photo Credit: Graphite Materials GmbH

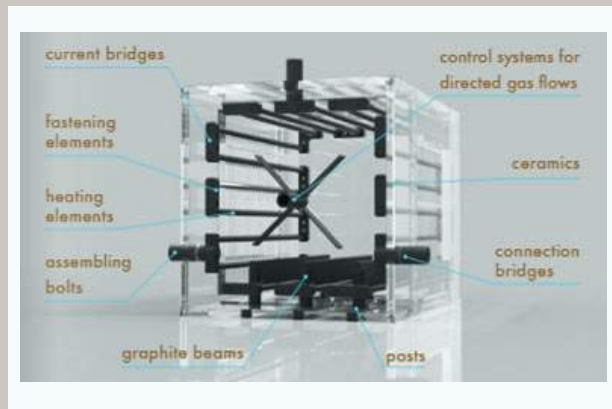

Photo Credit: Graphite Materials GmbH

Application of Graphite & CFC:

1. CFC Fixtures (Jigs & Tray)
2. Vacuum Furnace Components – Heating Chamber linings and repairs
3. Crucibles
4. High temperature Insulation
5. Roller conveyors in powder metallurgy

Benefits of using Graphite & CFC:

1. Dimensionally stable over high heat
2. Impact-resistant & break-proof
3. Light weight
4. Durable
5. Energy saving compared to metallic fixtures
6. Reducing downtime for the replacement of vacuum furnace components
7. Customizable
8. Minimal Distortion

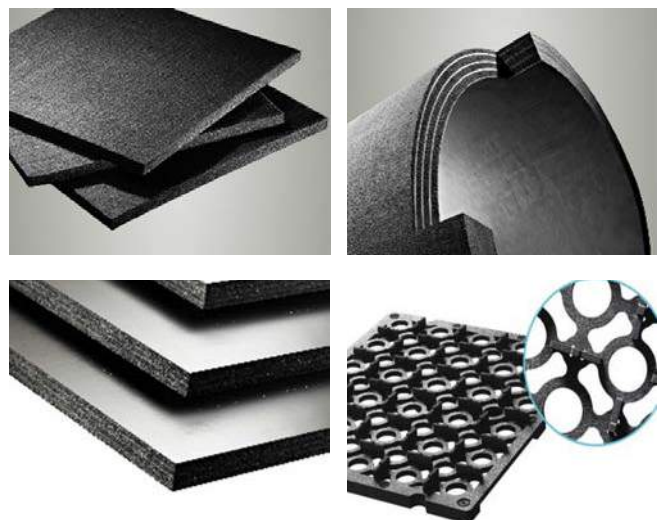

Combustion and Burner Technology

We provide and install a reliable and quality product in a wide range of burner products, industrial combustion and low NOx burners from manufactories worldwide for industrial furnaces and manufacturing sectors.

Our burners can be remotely controlled from an electrical panel that would have increased your work efficiency



High velocity premix burners



Dual fuel burners



Burner Sequence Controller



Infra-red Burner



Gas Valve Stand

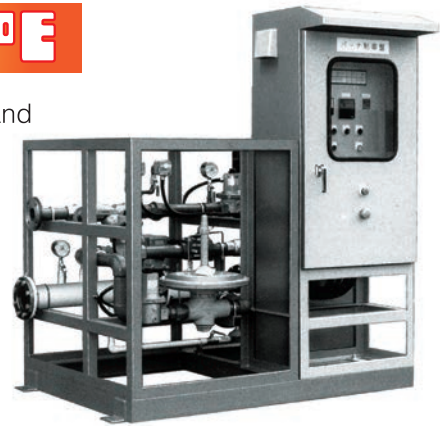

Reducing / Balance Regulator



GGLess Radiant Tube Burner

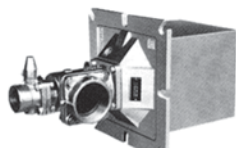

High speed burner



Gun type burner



Metal Knit Burners



Deodorizer



Painting robot & Booth



Continuous painting and drying furnace

Combustion Technology Service and Solutions



Engineering Services & Solutions :

- Design and Installation
- Overhaul and Maintenance
- Exhaust Ductwork and Insulation covering
- Adjustment and Calibration
- Piping system design and Installation

Common application of gas burner

- Foundry Industry → Steel, Aluminium, Copper, Brass (Non-Ferrous)
- Ceramic Industry → Ferrite, Porcelain, Ceramic ware, Tile, etc.
- Glass Industry → Melting & Holding
- Metallurgical Industry → Heat-treatment, Hardening, Forging, Annealing, Bright-annealing, Sintering, etc.
- Electronic Industry → Diffusion, IC substrates
- Chemical Industry → Reaction gas heating, Pigmentmaterial, etc.
- Other → Laboratory and research, Igniter oil and gas heater

Thermocouples and Temperature Control Systems

Our Products:

We supply various types of accurate thermocouples. We also provide design, manufacturing and installation of temperature control system as complete systems solution. In addition, to assure the accuracy of control systems and stability over the time, we also provide calibration services for thermocouples, temperature control systems and full heating



Our Services :

Temperature Uniformity System (TUS)

Temperature uniformity is defined as the maximum temperature deviation in the work space of the furnace. Temperature Uniformity in +/- K in the Standard Furnace set temperature with the work space of the empty furnace during the dwell time. Furnace should be calibrated accordingly.

In Order to provide value added for Thermocouple & Furnace system. We also provide system accuracy testing which covers:

1. Comparison reading & data of separate system that monitor same furnace
2. Monitoring & recording data during typical heating cycle while comparing reading general from both systems.



Industrial Control Panel Design & Engineering

Industry 4.0

Intelligent technology embedded in smart intuitive machineries

Connecting To The Future

Solution for control panels and communications



Our Solutions

- Design and assembly as per customer requirements
- Panels with digital & analogue I/O
- Improvement of users interface, touch panels/HMI
- Low Maintenance
- Supports IoT platforms

Furthermore, all our panels are tested prior to dispatch and follow the AS 3000, AMS 2750E, NADCAP, and CQI-9 standard.



Si3N4 Protection Tubes



TKR Mitsui Kinzoku Ceramics Division



Prolific Group is cooperating with TKR Mitsui Kinzoku Ceramics Division to supply high quality protective tubes for; Heater, Thermocouple which are used for preventing the corrosion from molten aluminum. Aside of that we also supplying stalks and degassing rotor shaft which are useful for processes in aluminum industry.

Made from high quality material such as: HI-CERA SN (Silicon Nitride Fine Ceramics), HI-CERA TB (Titanium Dioxide Fine Ceramics), HI-CERA SS (SiC Fine Ceramics); HI-CERA SC (Silicon impregnation SiC Ceramics); HI-CERA RS (Recrystallization SiC Ceramics); HI-CERA HA (Alumina Fine Ceramics); HI-CERA ZR (Zirconia Fine Ceramics); HI-CERA AZ (Alumina Zirconia Fine Ceramics)

Features of the materials are:

- Superior corrosion resistance for longer service life
- Excellent corrosion resistance to molten aluminum and electronic conductivity
- Exceedingly superior hot mechanical strength,
- High thermal conductivity
- Heat shock resistance
- Wear resistance
- Resistance against acids such as Hydrochloric Acid (HCl) and Sulfuric Acid (H₂SO₄) which allows acid cleaning of the parts.



Disperion of Gas (Water model)

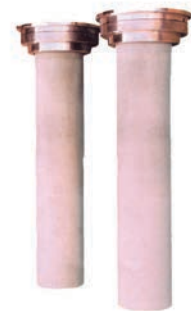

Stalk for Low Pressure Die Casting

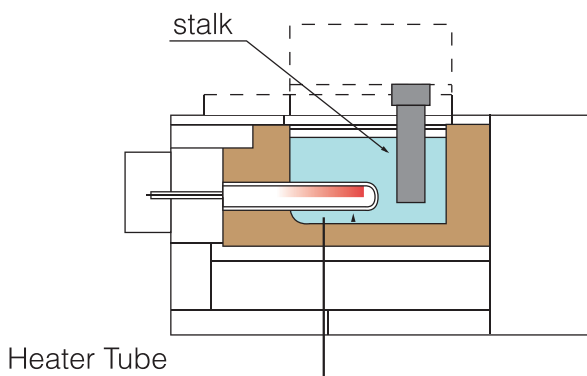
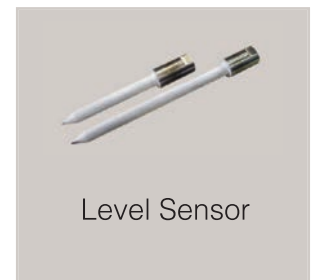
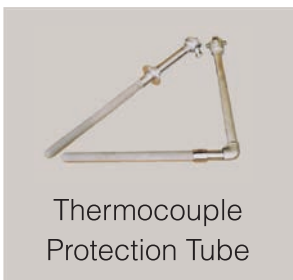

Horizontal Heater Tube Application

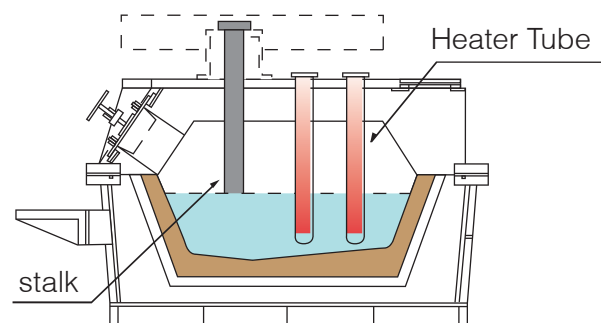

Vertical Heater Tube Application



ATHERM

ATHERM is a French company which has continuously improved skills in design and industrialization of thermal solution for 30 years.

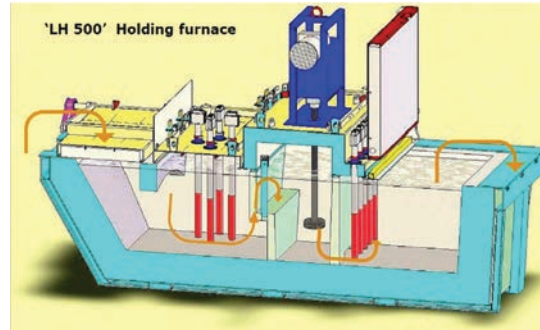

SAVE ENERGY

In comparison with alternative technologies the ATHERM ultra-compact immersion heating leads to **30% savings** and more.

SAVE METAL

Avoiding any over-heating, the ATHERM Immersion heating technology minimize oxides, drosses and corundum formations. Thus, the metal quality is improved and the losses of metal are dramatically dropping.

SAVE PRODUCTION TIME

Since the formation of oxides and corundum is reduced, you have less to clean the furnaces walls and heating elements, saving productive time.



Design of aluminum heating solution: Product range designed and customized to fit your needs



"Made in France" Quality: 700 immersion heaters per year



Technical assistance & Project management: Installation design phase assistance, commissioning and training assistance

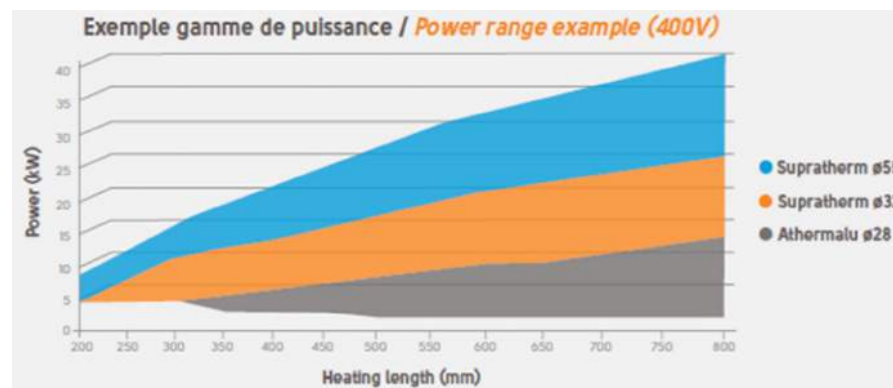

Centrifugal Casting Tube & Roller

Prolific Group has been working with one of the leading manufacturers in machinery materials under the continuous operation like from various casting system, Global Prime Metals (GPM) from South Korea. The wide application and experience for area such as steel industry, vehicle, petrochemical, industrial furnace, industrial machinery, construction industry, non-ferrous metal and etc; have been some of the competitive advantage of working with GPM.



GPM always strive to improve their special steel casting product to be reduce in energy efficient, durable, and easy to maintain.

Radiant Tube for Bright Heat Treatment Furnace (W-Type)

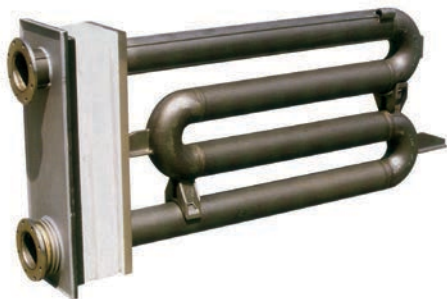

Radiant Tube (U-Type)

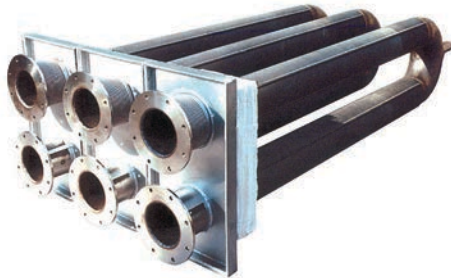

Sink Arm



Heart Roller & Heat Gauge Roller

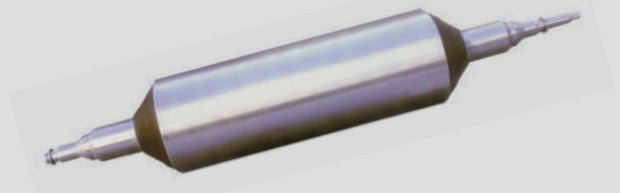

Heart Roller



Sink Roller



Stabilizing Roller

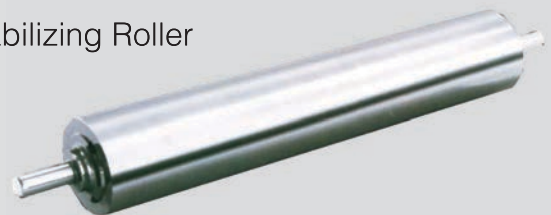

Rotary Retort



Casting Parts

With the experience to supply to many companies in South Korea and other countries such as POSCO, Hyundai Steel, Hyundai, KIA Motros, Bluescope, Kobelco and many more, through Prolific Heating International Co., Ltd; GPM has been expanding market to South East Asia.



Fan Wheel



Recuperator



Skid Riders

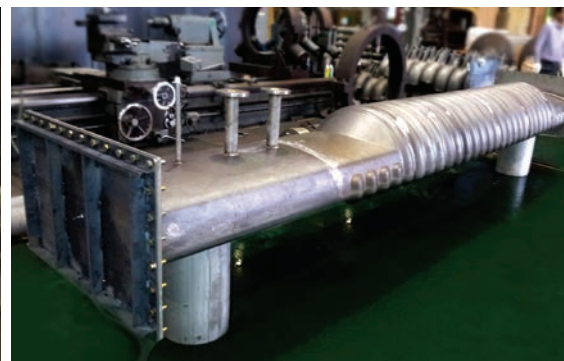

Casting Muffle

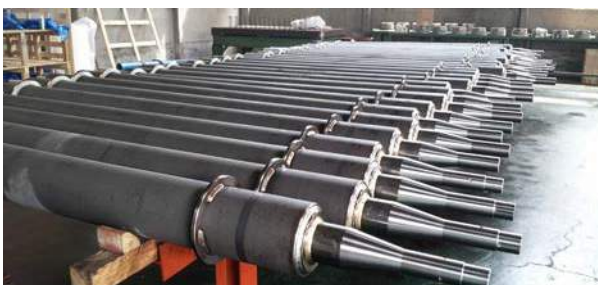

Furnace Roller

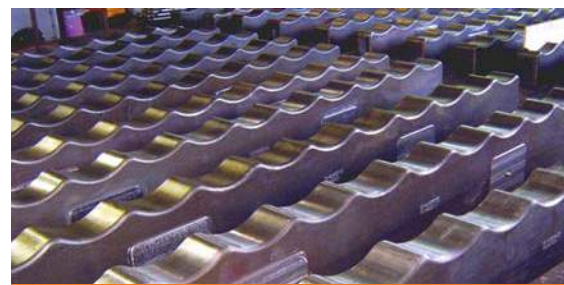

Walking Beam

Wire Conveyor Belt



Kansai Wire Netting

Prolific Group has been established long and fruitful cooperation with the maker for the wire conveyor from Japan; namely Kansai Wire Netting Co., Ltd



S-20-2.3-K (曲げタイプ knuckle type)

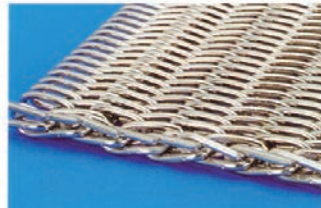

A2-8-14-3.2-3.0-C (引掛けタイプ clinch type)

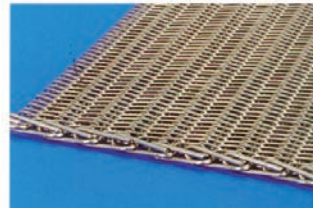

A2W-4-7-1.8-1.2-C (引掛けタイプ clinch type)

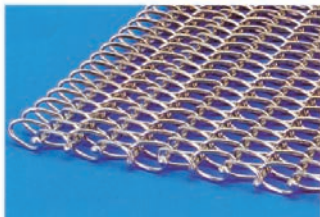

K2-10.1-12.7-1.8-1.8-W (溶接タイプ welding type)

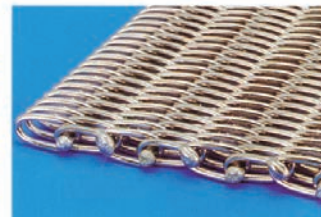

A2-8-14-3.2-3.0-W (溶接タイプ welding type)

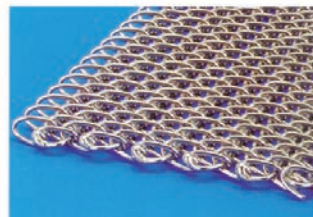

RR-10-10-2.0-2.0-W (溶接タイプ welding type)

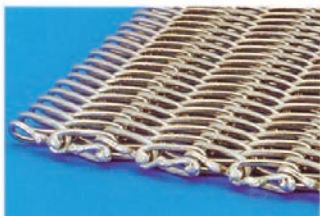

K2W-8.5-18-3.0-2.5-W (溶接タイプ welding type)



F2-7-16-4.0-2.6-RF (ロッドフランジタイプ rod flange type)



CFW-24-27.3-5.0-PH (プレート付タイプ with plate link)



スパイラルとロッドの折り曲げ方式
Spiral and rod bending type

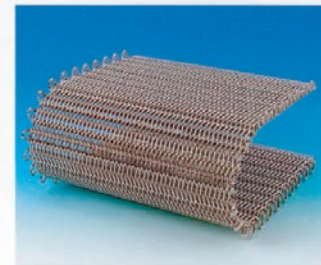

ロッドのみ折り曲げ方式
Rod bending type



U字型ロッド挿入折り曲げ方式
U-shaped rod insertion bending type

Special Type

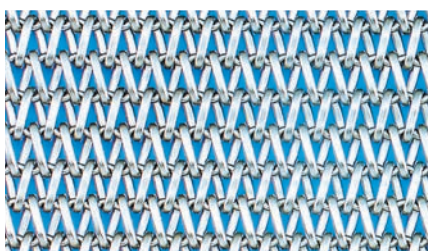

KF2-5-6.5-1.4-(1.2x1.6)

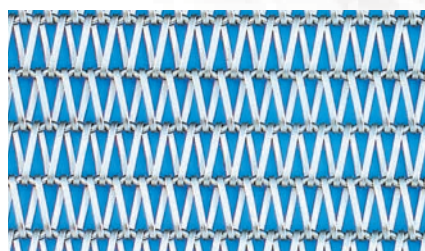

KF2-4-9-1.4-(0.6x1.2)

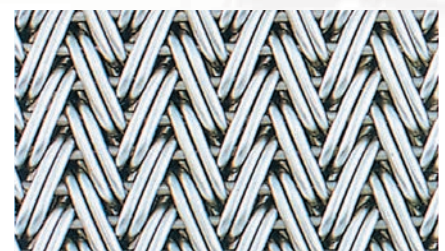

AW3-10-3.4-1.6-1.2

Production Process



Line of Business of Kansai Wire Netting Co., Ltd:

- Woven Wire Cloth
- Wire Conveyor Belt and System
- Metal Filter Element of Woven Wire Cloth, Sintered Wire Mesh and Sintered Metal Fiber
- Knitted Wire Mesh
- Wire Mesh for Vibrating Screen
- Test Sieve
- Wire Mesh Demister
- Perforated Metal Screen
- All other kinds of wire cloth

Industrial Application:

1. Heat Treatment Industry
2. Fastener Manufacturing Industry
3. Automotive Component & parts Industry
4. Food & Beverage Industry



Installation & Repair Service

The versatile application of the wire conveyor belt and its high quality have been one of the competitive advantage of our cooperation. With focus on the heat treatment application which require high temperature resistant and complemented by Prolific Group's ability to not only help customer install, but also clean, repair and maintain the mesh belt used in the furnace will be one of the value added advantage for customer.

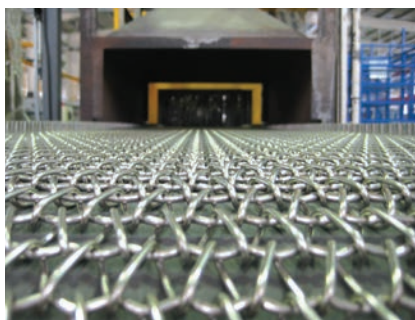

Insulation Technology



We import and supply insulator product from the leading manufacturer of refractory fibers products up to 1800°C. Not only producing standard products, our suppliers' will customize to fit the demanding requirements of specific applications.

The product range includes;

- Refractory components for furnace & kiln
- Fiber insulated heaters
- Molten metal delivery and handling
- Refractory for aluminium die casting

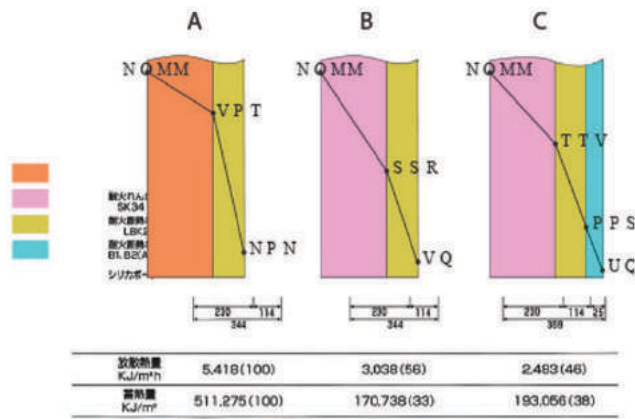
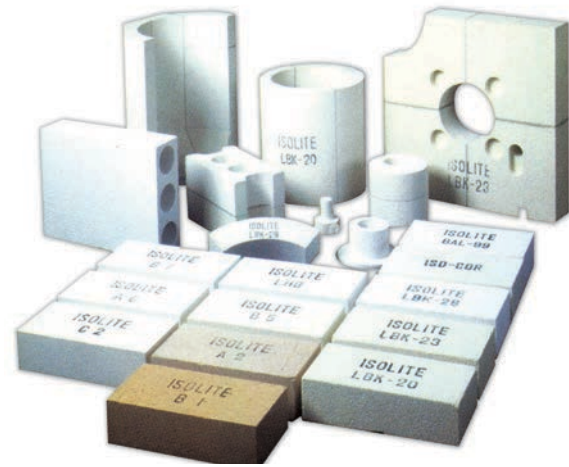

ISOWOOL - Bio Soluble
Fiber (AES Wool)

Product range PROMAFLEX



MONALITE shaped parts
for non-ferrous metallurgy

Environmentally
Friendly

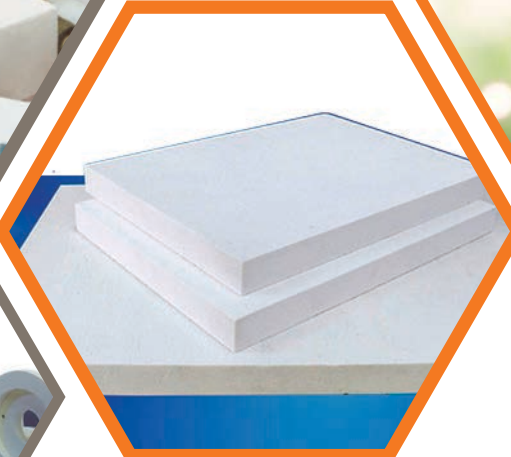

Nano-microporous Thermal
Insulation Board



Promat - Insulation Technology



Prolific Group in cooperation with Promat, supplying wide range of insulation technology to satisfy the demand for optimum planning, calculation and design, right down to the smallest details. Coordinated planning presupposes that the designer determines the physical and chemical requirements and factors of influence according to application. The most appropriate insulating materials, systems and components are then selected to provide maximum efficiency.

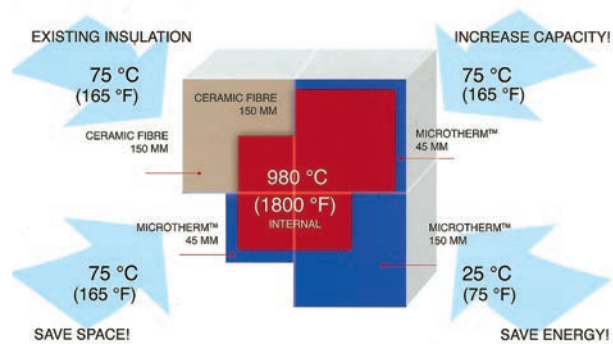
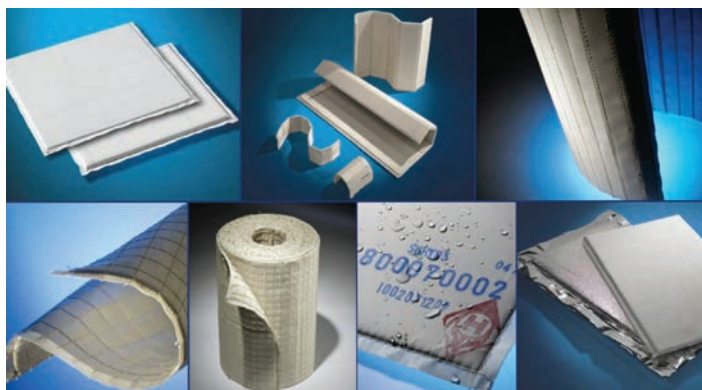

Refractory Service

Providing the solution in Refractory and insulation for all heating equipment ;

- New build
 - Repair
 - Maintenance and overhaul
 - Efficiency improvement
- Industry related ;
- Steel Industry
 - Aluminium Industry
 - Foundry
 - etc.

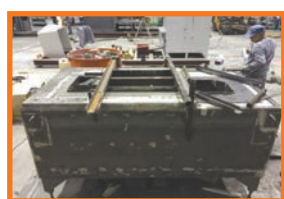

3. Install wood mold or setting



4. Lining (Refractory castable casting)

Lining

Setting

Lining fire brick



1. Install Support (Anchor)

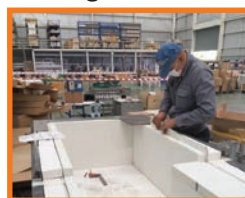

2. Install Back Lining (Insulation)

SiSiC Radiant Tube



Innovators in Composite Radiant Tube Technology

We are supplying special material from INEX whose specializes in Composite Radiant Tubes (CRTs) used for indirect heat-treating processes. The tube consist of Silicon Carbide (SiC) particles reinforcing a continuous Silicon (Si) metal-matrix formed using our patented infiltration process.

Introduced in 1988, these composite material completely eliminate common problems associated with metal alloy radiant tubes that suffer from Creep (deformation, distortion & rupture), Carburization (embrittlement & corrosion), Thermal Shock, Melt-Through, Weld Failure and Oxidation to 2450 F (1340*c)

Chage to INEX to quit changing your Radiant Tube!

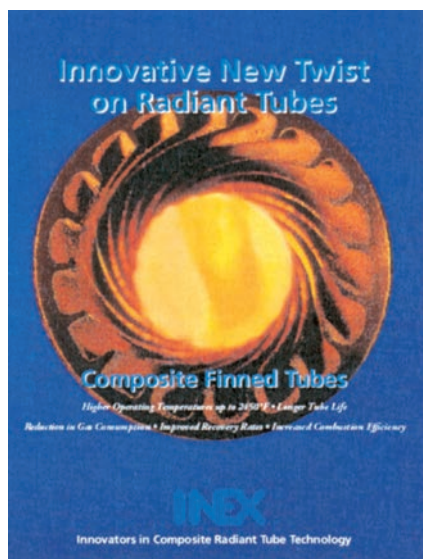
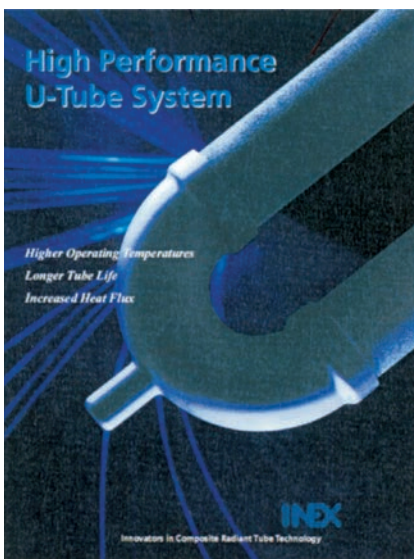

INEX @ 360 hours 600 Alloy @ 1 hour
Si-SiC Composite vs. 600 Alloy (after just 1 hour)
No deformation for the INEX tube 360 hours @2462

Alloy Engineering & Muffle

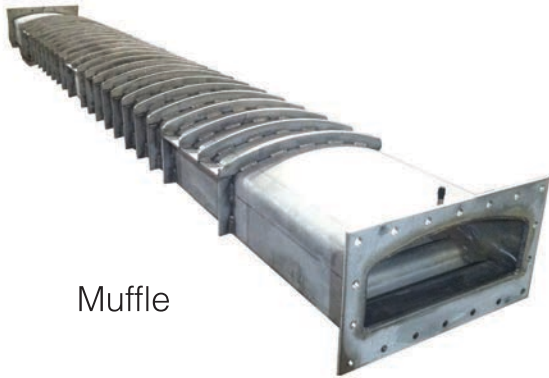
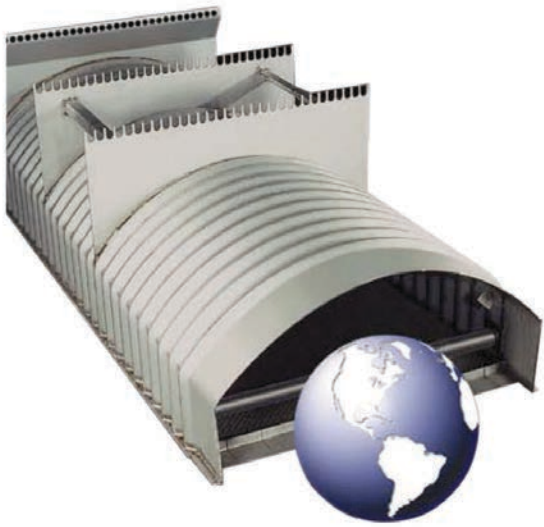

Muffle



Furnace Fan



Rotary Retort



Cylinder Retort

Innovative Design Solution

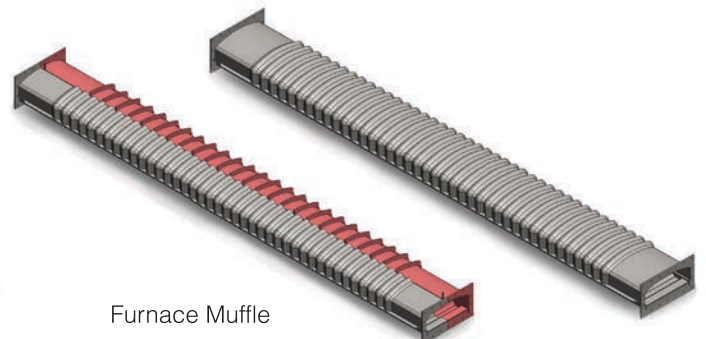
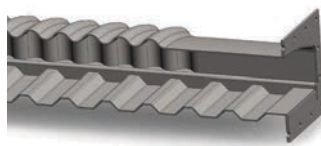
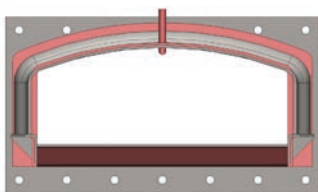

Furnace Muffle



High-Temperature, Corrosion-Resistant Products

Alloy Engineering designs and fabricates a complete line of high-temperature, corrosion resistant alloy products including :

- Industrial and high-temperature fans
- Muffles
- Rotary retorts, batch and continuous
- Pickling hooks
- Catalyst baskets
- ASME code vessels
- Forced air coolers
- Hydrogen annealing equipment
- Radiant tubes

Ceramic Engineering & Refractory

With the advanced manufacturing team and using various types of high ceramic and refractory in producing made to order accessories used in the industrial heating system. We cater various applications with highest efficiency.

Aluminium Oxide (Al_2O_3) is one of the major material that we use as it offers a combination of good mechanical properties and electrical properties leading to a wide range of applications.

Thus resulted in useful product characteristics such as:

- Good strength and stiffness
- Good hardness and wear resistance
- Good corrosion resistance
- Good thermal stability
- Excellent dielectric properties (from DC to GHz Frequencies)

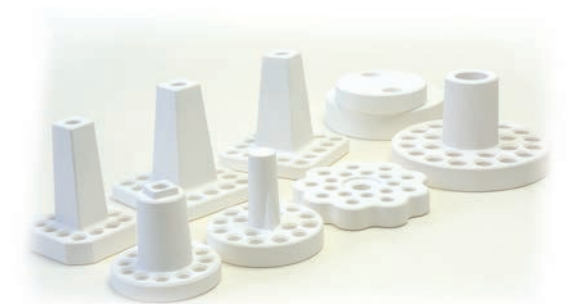
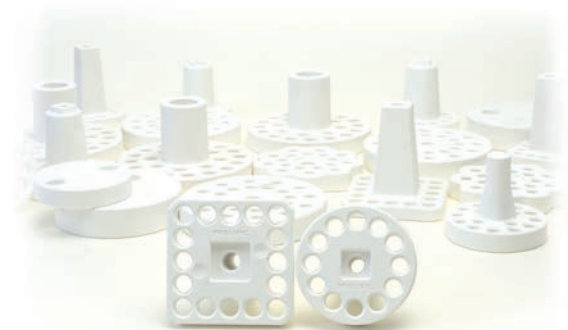

Ceramic Tube for Furnace



SiC Refractory



Ceramic Accessories for Kiln



Sintering High Alumina

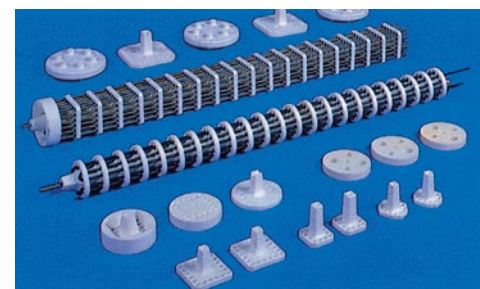

High Alumina Ceramic for Heater

Basket & Tray

With utilization of 3D Printers

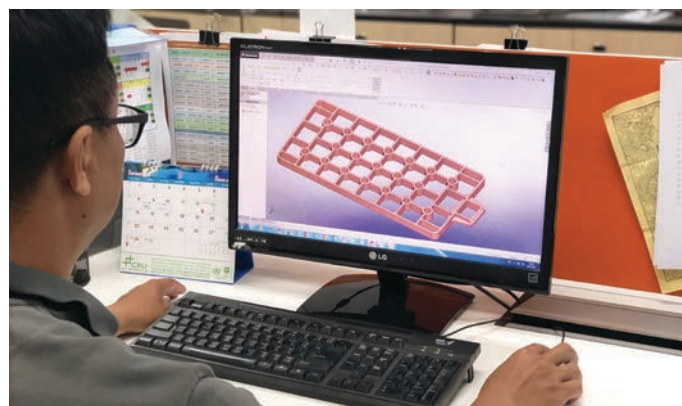

Cooperating with one of well-known jig & tray maker for heat treatment industries, Prolific Group proudly presenting a product line which fit to your production capacity. With our own designers in hand, we can design jig and tray to your needs, or based on your own furnace design.

We are capable to supply you Lost wax casting (SCH-13), sand casting, even stainless welding, with any materials match to your requirement.

Business Ranges

- * Heat-treatment jigs design, production and distribution
- Lost-wax products
- Sand casting products
- Stainless welding products
- * Various industrial furnace maintainance
- * Industrial furnace heater design, production and distribution
- * Various types of plant engineering and construction

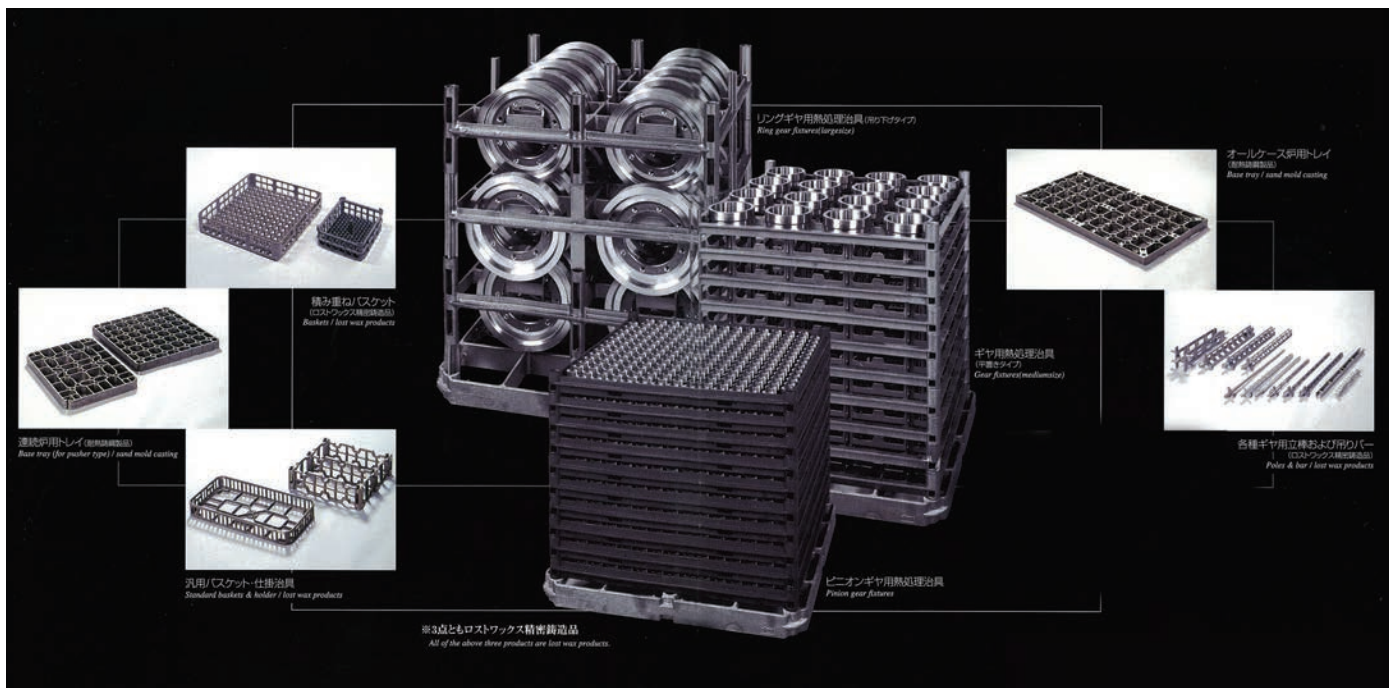

Carbon/Carbon composites have high mechanical strength, thermal conductivity, prolonged life, light-weight and offer businesses energy savings, increased productivity and an overall reduction in running costs.

C/C is a fundamental material to aid today's modern industries. Industries including ;

- Steel and alloy production
- Automotive and aerospace components to solar-cell manufacturing, glass production and electronics

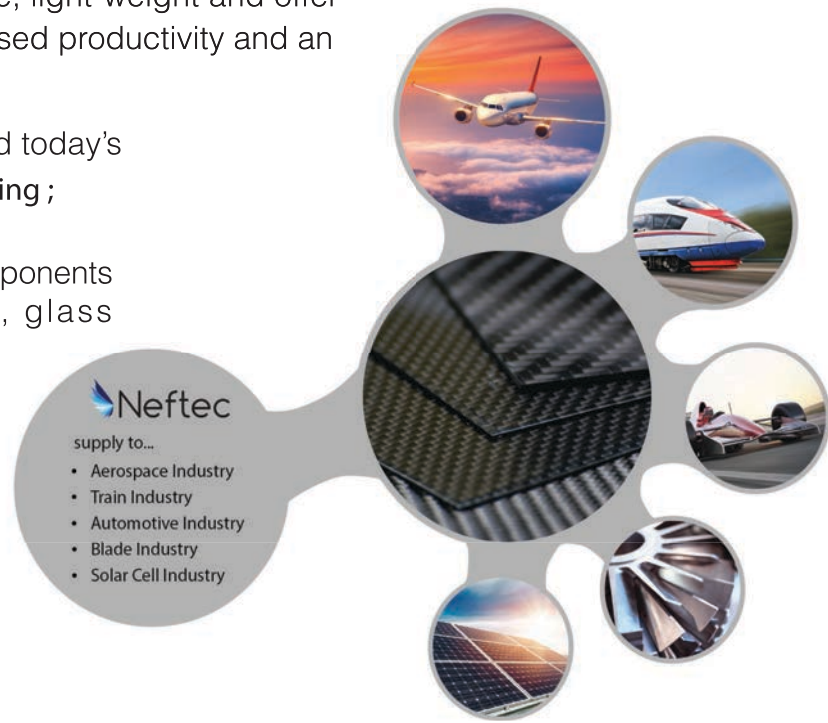

Key Benefits

- Over Graphite
 - Higher strength and structural rigidity
 - Higher resistance to fracture
- Over Ceramic
 - Higher resistance to fracture
 - Higher resistance to thermal shock
 - Carbon composites can be machined into complex shapes
 - Carbon Composites do not bond
- Over Metal
 - Can endure very high temperatures 2000°C (3600°F)
 - Lighter in weight-Carbon composites weight 1/5th of iron
 - Highly resistant to corrosion and radiation
 - Thermal expansion is far lower in Carbon composites
- Plastic/CFRP
 - Can endure very high temperatures

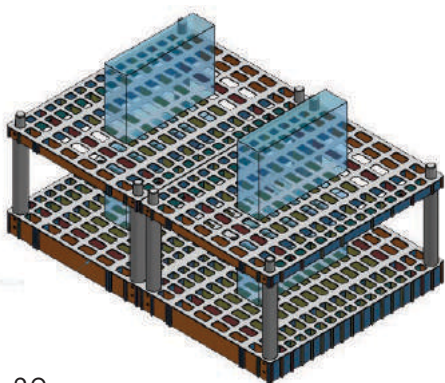

Supplementary Products

In addition to the supply of the critical spare parts of the furnace, we also include our product with supplementary product to increase the efficiency & productivity of your heating process. These are the supplementary products which Prolific Groups currently supplying:

Stainless Steel Curtain

Original Manufacture from Japan then fabricated in Prolific's Facility, we supply SUS304 H-TA Coil has high strength and low weight. Good corrosion resistance used for equipment, heat exchangers, piping, and other processing equipment that come into contact with fresh water. The purpose of this curtain is generally for to avoid the heat loss in the furnace.

Application: Brazing Furnace, Normalizing Furnace, cooling jacket of sintering furnace, etc.

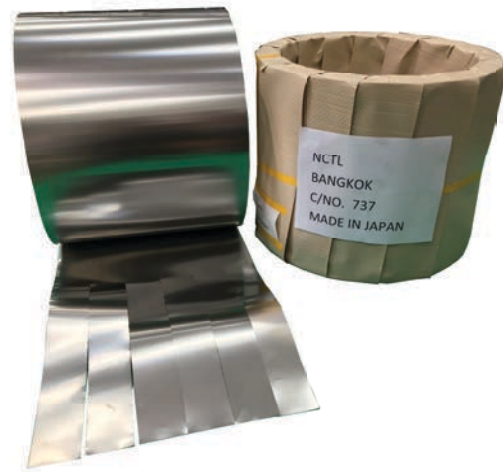

Three types of Nickel Catalyst:
Round, Cubic & Cylinder Form

Nickel Catalyst

Catalysis is a chemical phenomenon that increases the rate of a chemical reaction by spending only a tiny amount of additional substance, called a catalyst. In this case Nickel Catalyst is used in the gas generator in order to jumpstart the catalytic process that can be tuned for high cost efficiency.

Cleaning Solution for Heat Treatment

As one of the value added products to Heat Treatment Process, in order to achieve clean products, Prolific Group is in cooperation with HEMO GmbH, for one of their solution using Hydrocarbon with benefits such as solution to organic contaminants

such as hardening oil before annealing, suitable for use with CFC cracks, etc. The cleaning procedure with hydrocarbons or modified alcohols under vacuum conditions and increased levels provides best result even for complex part geometries. One of the advantage is easy integration, EMO has been cooperating with our partner IPSEN as well in supplying best all in one heat treatment services to our customers.



Before Cleaning



After Cleaning

Foundry Industries: Non-Ferrous

We are specialized in supplying the equipment and solutions for Non-ferrous industry which we offer extensive product range that is perfectly suitable.



Various Coating Agent

Coating Material

- For melting and holding furnace, hopper, ladle, melt level detective rod
- For preventing erosion and top coating for aluminum detachment



Silicon Carbide Crucible



Silicon Carbide Crucible for melting and holding furnace for foundry industries, Silicon Carbide Crucible, Pyrometer tubes, Degassing tube, Launder etc.



Morex SCN high thermal conductivity and high corrosion resistance as thermocouple protection tube for light alloys.



ARSAL 2125 High effective flux to remove oxide and prevent the corundum on furnace wall
Flux For the treatment of the alloys is carried out for

- Cleaning
- Treatment the dross
- Grain refining
- Release agent

NOTORP
Hydrogen Analyzer



Hydrogen Analyzer Hydrogen Analyzer Innovative hydrogen concentration analyzer designed for molten aluminum alloys

Foundry Industries: Non-Ferrous

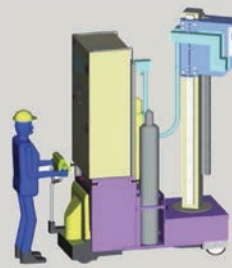

MBS 3000



MBS 4000

Degassing and cleaning Machinery and plant equipment for foundries, combined treatment for degassing and cleaning of fluid aluminium

Vacuum Density Tester For Casting density index sample, the consistently high quality the melt is assured and reject rate effectively reduced

- User – friendly
- Process reliable
- Fully electronic



Vacuum Density Tester 3VT basic



Mobile Heater



Relining



Installation & Tune up System

Our Services Support

- Design
- Fabrication
- Installation
- Calibration
- Tune up system
- Preventive Maintenance
- Relining
- Wiring and Piping

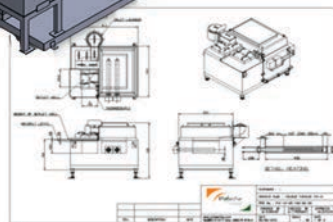
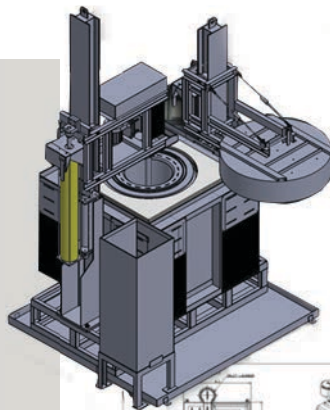

Prolific Engineering and Services (PES)

“One Stop Service”

To complement the brand agency at the PHI, PES under the same Prolific Group, completing the capability as the Engineering Service body, as well as partnering with furnace makers such as IPSEN, Nabertherm, & Gasden Ro for their local after sales service in Thailand and neighboring country. Aside of that support Katsura & Hope burner for the periodic maintenance & repair of the combustion system.

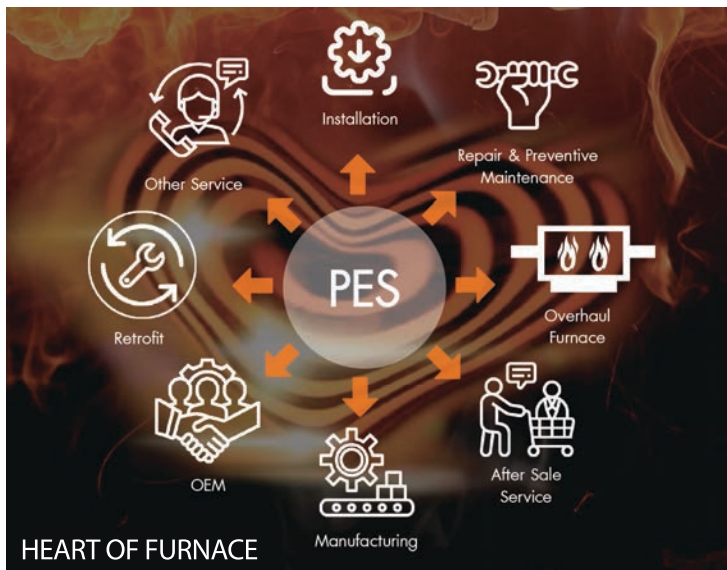

Nabertherm

MORE THAN HEAT 30-3000 °C

With the experience to sell Nabertherm furnace for over than 8 years, finally Prolific Group has been appointed as the Official Agent of Nabertherm for Thailand. With the wide range of furnaces application & sizes; we are proud to support Nabertherm to supply:

- Glass Industry
- Arts & Crafts Industry – Including Ceramics, Porcelain, Sanitary Wares Manufacturer
- Advanced Materials Industry – Including Powder Metallurgy, Technical Ceramics, Bio Ceramics, 3D-Printing, MIM, CIM, Fuel Cell, Precious Metals & stones etc.
- Additive Manufacturing Industry
- Laboratory Industry
- Dental Industry
- Thermal Process Technology Industry
- Foundry Industry



KTR 3100 DT with rotating system for tempering of silicone parts. Four baskets will be charged in the frame and can be taken out separately



Rotary tube furnace RSRB 80/500/11 as tabletop version for batch operation



Turnkey Project of Vacuum Furnace & Atmosphere Furnace



Titan Turbo Treater Super Turbo TinyTurbo Vertical Turbo Argo



Batch Furnace Systems Continuous Furnace System

Repair & Overhaul of IPSEN's Furnace (IPSEN After-Sales Service)

With the many IPSEN Furnaces in Thailand, PES in coordination with IPSEN, supplying not only spare part of the furnace, but also repair & overhaul of its furnaces.



Insulation Overhaul



Repair of CFC Insulation



Overhaul of Hot Chamber



Spare part of IPSEN Furnace

Prolific Activity

Awards



Seminar



Exhibition



Company Outing



Customer Reference

Hitachi Chemical
Working On Wonders

TFS

mazda

Minebea
Passion to Exceed Precision

EXEDY
EXEDY (Thailand) Co., Ltd.

BLUESCOPE
STEEL

DENSO

TOYOTA
TOYOTA DAIHATSU
ENGINEERING & MANUFACTURING CO., LTD.

AIA
AISIN AI CO., LTD.

NIPPON STEEL

posco
THAINOX

AGC

NSK
BEARINGS

Thai Parkerizing Co., Ltd.

EthosEnergy

Valeo

Jatco
The mission is passion.

LIXIL
TogTEM

CHROMALLOY

TOSHIBA

MUSASHI

MUSASHI

HITACHI
Inspire the Next

Triumph Group

JFE

SOMBOON GROUP

SMOH

NT
THAI PARKERIZING CO., LTD.

UACJ

Burner

Burner

Combustion and Burner Technology

Our Burner Division focuses on gas burner products, and system for Industrial Furnace and Thermal Technology
"Optimized Technology for your wide improvement"

Founded:

Type of Business:

- Design
- Manufacturing
- Authorized brand distributor
- Service of Burner and Accessories

PSB

PSB (Prolific Group)

Prothermal Solutions Business (PSB)
Solution based business focused on improvement of productivity and efficiency in thermal requirement.

"Maximize your Profitability through PSB"

Founded : January 2015

Type of Business :

- Cost effective materials
- Innovation and machinery improvement of machinery
- Methodology Improvement
- Overall Resources Development

Non-ferrous

Non-Ferrous

Non-ferrous Products and Innovation

Our Non-Ferrous Division focuses on Non-Ferrous metal industrial products and services provider
"Providing Non-Ferrous Products and Solutions for Excellence"

PES

PES

Prolific Engineering & Service Co., Ltd

Our company is a furnace designer, maker, and related services provider

"Heart of Furnace"

Established on : December 12, 2012

Line of Business :

- Design & Manufacturing
- Repairing & Preventive Maintenance
- OEM
- After services (IPSEN & GasDen Ro, Katsura Nabertherm)
- Other Services

PHI

PHI

Prolific Heating International Co., Ltd.

Our company is one stop of services provider in industrial heater and Burner products

"Our Heat is your Improvement"

Founded : July 20th, 2005

- Type of Business :
- Trading
 - Brand Agency
 - Design
 - Manufacturing



www.phiheating.com

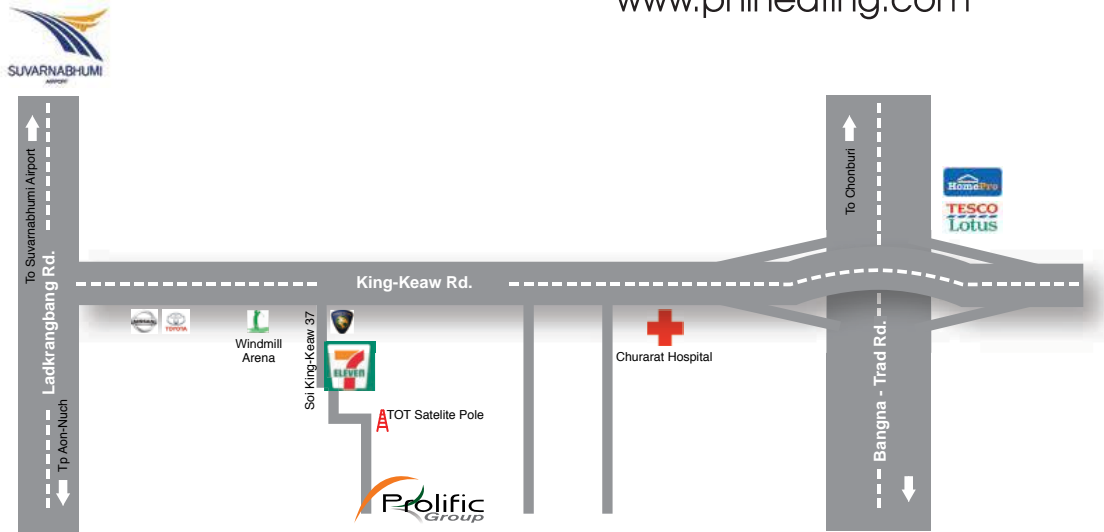

11/11 Moo 11 Soi Kingkaew 37,
Kingkaew Rd., Rachathava, Bangplee,
Samutprakarn 10540 Thailand



Management System
ISO 9001:2015
www.tuv.com
ID 9105080820



☎ : (662) 170-8171 (Auto 6 Lines)

📞 : (662) 170-8178, (662) 170-8179

📱 : Prolific Group

🌐 : www.phiheating.com

